

HARSHMAN BRIDGE
(Four Mile Bridge)
Spanning Four Mile Creek, Concord-Fairhaven Road
Fairhaven vicinity
Preble County
Ohio

HAER OH-126
OH-126

PHOTOGRAPHS

PAPER COPIES OF COLOR TRANSPARENCIES

WRITTEN HISTORICAL AND DESCRIPTIVE DATA

REDUCED COPIES OF MEASURED DRAWINGS

FIELD RECORDS

HISTORIC AMERICAN ENGINEERING RECORD
National Park Service
U.S. Department of the Interior
1849 C Street NW
Washington, DC 20240-0001

HISTORIC AMERICAN ENGINEERING RECORD

HARSHMAN BRIDGE (Four Mile Run Bridge)

HAER No. OH-126

LOCATON: Spanning Four Mile Creek at Concord-Fairhaven Road, Fairhaven vicinity, Preble County, Ohio
UTM: 16.691207.4397122, Fairhaven, Ohio Quad.

STRUCTURAL TYPE: Modified Childs through truss covered bridge

DATE OF CONSTRUCTION: 1894

DESIGNER/
BUILDER: Everett Sherman, superstructure; James M. Acton, masonry

OWNER: Preble County, Ohio

PREVIOUS USE: Vehicular bridge

PRESENT USE: Vehicular bridge

SIGNIFICANCE: Harshman Bridge is one of seven Childs trusses in the United States. Patented in 1846 by Horace Childs of New Hampshire, the Childs truss never came into the mainstream of covered bridge building, but Everett S. Sherman, an Ohio bridge builder, revived its use in the late nineteenth century.

AUTHORS: Lola Bennett, Historian, October 2003
Megan Reese, Engineering Technician, and Dario A. Gasparini, Ph.D., Professor of Civil Engineering, Case Western Reserve University, Summer 2003

PROJECT INFORMATION: The National Covered Bridges Recording Project is part of the Historic American Engineering Record (HAER), long-range program to document historically significant engineering and industrial works in the United States. HAER is administered by the Historic American Buildings Record/Historic American Engineering Record, a division of the National Park Service, U.S. Department of the Interior. The Federal Highway Administration funded the project.

Chronology

- 1803 Ohio becomes seventeenth state admitted to the Union.
- 1805 America's first covered bridge built at Philadelphia.
- 1807 Horace Childs born at Henniker, New Hampshire.
- 1809 Ohio's first covered bridge built across Little Beaver Creek in Columbiana County.
- 1829 Orlistus Roberts and James Campbell build Preble County's first covered bridge (see HABS No. OH-2229, Roberts Bridge).
- 1831 Everett Sherman born at Delaware County, Ohio.
- 1836 Horace Childs builds his first covered bridge at Haverhill, New Hampshire.
- 1846 Horace Childs patents Childs truss.
- 1867 Everett Sherman builds his first bridge at Sunbury, Ohio.
- 1883 Everett Sherman uses Childs truss for Chambers Road Bridge (Delaware County, Ohio).
- 1886 Cyclone destroys many bridges in Preble County, Ohio.
- 1886 Everett Sherman moves to Preble County, Ohio.
- 1887 Everett Sherman builds his first covered bridge in Preble County, Ohio.
- 1894 Harshman Bridge constructed.
- 1896 Everett Sherman builds Preble County's last covered bridge.
- 1897 Everett Sherman dies at Eaton, Ohio.
- 1900 Horace Childs dies at Henniker, New Hampshire.
- 1960 Southern Ohio Covered Bridge Association (now known as the Ohio Historic Bridge Association) formed.
- 1963 Harshman Bridge roof blows off in a windstorm.
- 2003 Harshman Bridge recorded by the Historic American Engineering Record.

Introduction

The first documented covered bridge in Ohio was built in 1809 across Beaver Creek in Columbiana County.¹ Historians estimate that there were once as many as 4,000 covered bridges in Ohio, more than any other state in the nation.² Over time, these structures were lost to fire, floods, neglect and replacement. A list published by the state in 1937 indicates that, at that date, there were 609 covered bridges in Ohio. That number dropped dramatically in the 1950s, as covered bridges were replaced with modern spans. Today, Ohio has 135 surviving covered bridges.

Description

The Harshman Bridge is a single-span modified Childs truss covered bridge on stone masonry abutments with heavy parging.³ The bridge is 109' long, with a clear span of 94'-6". The trusses are 13'-0" high from the top of the upper chord to the bottom of the lower chord and 17'-7" apart on center, with a 15'-6" wide roadway. The bridge structure and housing are square to the roadway, but the abutments are skewed at nearly 30 degrees. There is a nonstructural dummy panel on the short end of the trusses (northwest and southeast corners) to accommodate this skew.

Each truss has twelve panels, plus a dummy panel, framed together as a modified Childs truss. The upper chord consists of two lines of 8"x8" timbers, spliced together with boards and bolts. The lower chord is composed of two lines of 7"x12" timbers spliced and bolted together. The upper and lower chords are connected by 7"x7" vertical posts, diagonal tension rods (1" diameter in panels 5 and 8, 1¼" diameter in all the other panels, except no rods in the center panels) and single diagonal braces (graduated in size from 3"x12" in the center panels to 8"x12" in the end panels) in each panel. There are wooden bearing blocks between the posts and compression diagonals. The rods pass through a hole in each wooden diagonal and are held in place above the upper chord and below the bottom chord with an angle block, an iron casting and a nut. As the timber shrinks, the metal rods can be tightened to adjust the camber of the bridge.

The floor system is composed of 6"x13" transverse floor beams suspended from the lower chord. Lower lateral bracing is 4"x5" sticks crossing between the floor beams. There are thirteen lines of 3"x6" stringers laid longitudinally on top of the floor beams. The sub-floor consists of 3"x10" planks laid transversely on the stringers. The wearing surface is 2"x8" planks laid longitudinally on the sub-floor. Modern 6"x12" steel I-beams have been added below each floor beam with loop-welded hanger rods.

¹ Miriam Wood, *The Covered Bridges of Ohio, an Atlas and History* (Columbus: Old Trail Printing Company, 1993), p. 119.

² In 1970, covered bridge historian Richard Sanders Allen published a conservative estimate of 2,000 covered bridges. More recent historical research has doubled that estimate.

³ The bridge's name comes from Joseph Peter Harshman, who owned property adjacent to the bridge in the late nineteenth century.

The upper lateral system is composed of 7"x7" transverse tie beams seated on the upper chord resting on the upper chord at each panel point and 4"x4" lateral diagonal bracing between the beams. Wooden 2"x4" rafters, spaced 18" apart, rest on the upper chord and rise diagonally up to a 4"x4" ridge pole. The rafters support a series of 1"x3" purlins, to which is fastened a standing seam metal roof. The exterior of the bridge is covered with 9" wide vertical board sheathing fastened to wooden nailers on the exterior faces of the trusses. The portals project forward over the approaches and have boxed end posts and ornamented gables. There is a small square 18"x18" window opening on each side of the bridge.

History

According to the 1858 map of Preble County, present-day Fairhaven-Concord Road originally skirted the west bank of a horseshoe bend at this location. Sometime prior to 1871, the road was straightened and two bridges built across the base of the horseshoe, but no information has been found concerning those bridges.⁴

In 1894 the Preble County Commissioners advertised in the local newspaper "for the building of a wood bridge over Four Mile Creek on Concord and Fair Haven Free Pike Road, near J.P. Harshman's in Dixon Township."⁵ On September 1, the Preble County Commissioners awarded the contract for the bridge to E.S. Sherman for \$14 per lineal foot and the masonry to J.M. Acton. No information has been found in local newspapers concerning the construction of the bridge. Presumably it was completed in late 1894 or early 1895. According to one source, stone for the abutments was hauled from Stone Point Quarry.⁶ The total cost of construction was reportedly \$3,184.⁷

Design

Horace Childs (1807-1900) was born at Henniker, New Hampshire, the son of Solomon Childs, a millwright. While attending school at Hopkinton Academy, Horace Childs lived and worked with his uncle, Col. Stephen H. Long (1784-1864), a nationally recognized civil engineer and bridge builder.⁸ Horace and his brothers, Enoch (1808-1881) and Warren (1811-1888), served as agents for Long and built dozens of covered bridges based on his 1830 truss patent. Eventually, Horace Childs struck out on his own and began securing contracts for railroad bridges. In 1846, he obtained a patent for a combination truss bridge with wood braces and iron counterbraces that improved on the simple bearing connections of Colonel Long's design by using bolts to secure the compression members.⁹

⁴ The present bridge south of Harshman Bridge is a concrete and steel stringer structure.

⁵ Harshman's name appears on the property adjacent to the bridge on the 1894 map. *Eaton Democrat* (Eaton, Ohio), 1894.

⁶ Ione Sell Heistand, editor, *Preble County, Ohio* (Eaton, Ohio: Preble County Historical Society, 1992), p. 18.

⁷ Seth Schlotterbeck, *Covered Bridges of Preble County, Ohio* (Eaton, Ohio: Preble County Historical Society, 1976), p. 8. *Preble County Commissioners Records* document payments of at least \$2,902.24 for the bridge.

⁸ For more on Col. Stephen Long and the Long truss, see HAER No. OH-122, Eldean Bridge.

⁹ Horace Childs, U.S. Letters Patent No. 4,693, 12 August 1846.

Childs truss covered bridges were built in New England in the mid-nineteenth century, but the type never came into the mainstream of covered bridge building.¹⁰ For reasons yet unknown, the Childs truss experienced a revival in Ohio from 1883 to 1896, when Everett S. Sherman built at least sixteen covered bridges based on this obsolete design. Seven of these covered bridges survive:

35-21-04	Chambers Road Bridge	Delaware County, OH	1883	73' Childs truss	E.S. Sherman
35-68-06	Brubaker Bridge	Preble County, OH	1887	85' Childs truss	E.S. Sherman
35-68-04	Dixon Branch Bridge	Preble County, OH	1887	50' Childs truss	E.S. Sherman
35-68-12	Christman Bridge	Preble County, OH	1894	92' Childs truss	E.S. Sherman
35-68-03	Harshman Bridge	Preble County, OH	1894	104' Childs truss	E.S. Sherman
35-68-13	Geeting Bridge	Preble County, OH	1894	100' Childs truss	E.S. Sherman
35-68-14	Warnke Bridge	Preble County, OH	1896	52' Childs truss	E.S. Sherman

Builder

Born in 1831 at Delaware County, Ohio, Everett Sherman learned carpentry from his father and built his first bridge at Sunbury, Ohio, in 1867.¹¹ In 1877, Sherman received a patent for a simple wood and iron truss bridge, but the design he made famous was the 1846 Childs truss.¹²

Everett Sherman's revival of this unusual type in the Midwest remains a mystery, although Sherman's second wife, Terissa, was reportedly related to the Childs-Long family of bridge builders.¹³ It is also probable, as historian David Simmons has conjectured, that Sherman read about expired truss patents in a series of articles published by *Engineering News* in 1882.¹⁴

¹⁰ One of these is documented in a report of the Concord & Claremont Railroad published in 1884, which states that a railroad bridge at Contoocook, New Hampshire, was a covered bridge "of the Child's plan...is very old, and should be...rebuilt soon as practical."

¹¹ Seth Schlotterbeck, "Builder of Many Bridges Lived Here," undated newspaper article in clipping files of Preble County Historical Society, Eaton, Ohio.

¹² Utz Road Bridge (1887), spanning Rape's Run in Preble County, is the only surviving example of this type. Evrett [sic] S. Sherman, U.S. Patent No. 191,552, June 5, 1877.

¹³ Sherman's first wife, Julia, died in Delaware County, Ohio, in 1864. The 1880 federal census indicates that Sherman's second wife was a native of Vermont, but no further documentation has been found to date to trace her ancestry.

¹⁴ David Simmons, "Unique Covered Bridge in Delaware County," *Ohio County Engineers News* (Spring 1991). F.B. Brock, "Truss Bridges: An Illustrated Historical Description of all Expired Patents on Truss-Bridges, Which Under the Law are Now Public Property and Free to be Used by Any One," *Engineering News and American Contract Journal* (December 16, 1882), p. 433.

When Everett Sherman revived Horace Childs' design in 1883, he borrowed the basic truss geometry, but did not use the inventions claimed in the patent. In addition, he modified the size of the web members based on the loads each would carry, instead of making them uniform size as specified in Childs' patent.¹⁵ In doing so, Sherman used contemporary engineering analysis to update an obsolete bridge design.

In 1886, Everett Sherman moved to Preble County, Ohio, after a storm destroyed most of that county's bridges.¹⁶ According to Preble County records, in 1886-87, Sherman built fifteen small bridges based on his 1877 patent and from 1886-1896, he built at least fifteen traditional covered bridges, all but one based on the same modified version of the Childs patent truss he had previously used in Delaware County.¹⁷

By the mid-1890s, public opinion was leaning in favor of modern metal bridges.¹⁸ Everett Sherman built Preble County's last covered wooden bridge in 1896. He died the following year at the age of 66.

¹⁵ All but one of the known Sherman-built Preble County covered bridges were built this way.

¹⁶ Sherman reportedly came to Preble County at the urging of Preble County Engineer Robert Eaton Lowry. Lowry was also a Delaware County native, and the two men presumably had a prior personal or professional relationship.

¹⁷ The Utz Road Bridge (1887) in Twin Township is the only surviving example of this type. The Utz Road Bridge *could* be considered a covered bridge, in that the top chords are covered with galvanized sheet metal. In 1966, the Ohio Covered Bridge Committee passed a resolution "to preserve this structure for posterity."

¹⁸ *Eaton Register* (Eaton, Ohio), 6 February 1896, p. 3.

Appendix A: Preble County Covered Bridges Built by Everett S. Sherman

	Pence Schoolhouse Br.	1886-1958	Central Rd./Banta's Fork	Childs truss	E.S. Sherman
	Brown Bridge	1887-1953	SR 725/Christman Branch	Childs truss	E.S. Sherman
	Eby Schoolhouse Bridge	1887-1956	Enterprise Rd./Lesley Run	Mult. kingpost	E.S. Sherman
35-68-04	Dixon Branch Bridge	1887	Moved to Lewisburg Park 1964	Childs truss	E.S. Sherman
	Beam Bridge	1887-1976	Paint Rd./Elkhorn Creek	Childs truss	E.S. Sherman
35-68-06	Brubaker Bridge	1887	Brubaker Rd/Sam's Run	Childs truss	E.S. Sherman
	Winchester Bridge	1888-1947	Enterprise Rd./Lesley Run	Childs truss	E.S. Sherman
	Lexington Bridge	1888-1950	Lexington Rd./Twin Creek	Childs truss	E.S. Sherman
	Duffield Bridge	1890-1933	SR 127/Seven Mile Creek	Childs truss	E.S. Sherman
	Sloane Bridge	1891-1958	SR 726/Banta's Fork	Childs truss	E.S. Sherman
	Tucker Bridge	1893-1961	State Rd./Four Mile Creek	Childs truss	E.S. Sherman
35-68-12	Christman Bridge	1894	Eaton Rd./Seven Mile Creek	Childs truss	E.S. Sherman
35-68-03	Harshman Bridge	1894	Concord Rd./Four Mile Creek	Childs truss	E.S. Sherman
35-68-13	Geeting Bridge	1894	Price Rd./Price Creek	Childs truss	E.S. Sherman
35-68-14	Warnke Bridge	1896	Swamp Rd./Swamp Creek	Childs truss	E.S. Sherman

Appendix B: Engineering Report

Objectives of Report

This report describes the structural behavior of the Harshman Bridge, built in 1894 by Everett S. Sherman over Four Mile Creek in Preble County, Ohio. The basic form of this bridge resembles the Childs truss, patented in 1846 by Horace Childs. The Childs truss utilizes both wooden and wrought iron members in its form, but unlike other wood and iron truss types, such as the Howe or Pratt, the Childs truss does not involve prestressing in its design. The main objective of this report was to quantify the behavior of the Harshman Bridge through physical experiments and dead load, live load, and creep analyses. Another objective was to compare the Childs truss form to its contemporary truss types, Long, Howe, and Pratt.

Scope of Work

Physical experiments on the bridge, including tightening of a tension rod and load tests with a 12-ton truck, were conducted in order to assess the behavior of the Harshman Bridge and compare results with analytical studies of the bridge. Plane truss and plane frame models were used for the dead load analyses and one live load analysis to compare the results of manual versus computer structural analyses. This was done mainly to determine how close the manually calculated plane truss models, which existed at the time Sherman constructed his bridges, correspond to the computer analyses. Live loads considered include a unit load at midspan, a unit load traversing the length of the truss, and a uniform live load over half-span and over full span. A tightening analysis was performed to assess the effects of tightening the nuts after the dead load was active. The effects of time-dependent behavior of wood on the Harshman Bridge were also studied.

Observations

Two physical experiments were conducted on the Harshman Bridge. Test 1 was simply the loosening and tightening of tension rod U_0L_1 , which was intended to model the physical tightening of the rods during construction. Manual tightening produced an axial force of 2300 lbs. Test 2 involved traversing the bridge with a 12-ton truck. Three runs were made, and the results were compared with the various analyses of the bridge.

For the dead load analyses, manually calculated stresses in a plane truss model were compared to the computer-calculated stresses in a plane frame model. Results from the two analyses were similar, with maximum forces of over 50 kips for both the top and bottom chord, about 10 kips for the verticals, about 23 kips for the compression diagonals, and 9.3 kips for the tension rods. The ratio of vertical components of forces in the diagonal members of the plane truss model was assumed to be proportional to the axial stiffnesses of the members. This underestimated the force taken by the tension rods as predicted by the plane frame analysis. The contributions of bending moments to the maximum normal stress in the elements were calculated, resulting in contributions between 10 and 40 percent of the total stress. The vertical midspan displacements predicted with the two models were 0.834" for the plane truss and 0.773" for the plane frame, which shows the contributions of member bending stiffness to the bridge stiffness.

Both plane truss and plane frame models were used to analyze a live load condition of a unit vertical force at midspan, again to compare the predictions of both models. Results yielded correspondence similar to that of the dead load analyses. The ratio of vertical components of force in the diagonal elements was again assumed to be proportional to the axial stiffnesses of the elements for the plane truss model. This underestimated the axial force in the tension rods as predicted by the plane frame analyses. The contributions of bending moments to element stresses in the plane frame model were determined to range between 20 and 60 percent. The vertical midspan displacement of the plane truss model, 0.0308", was again higher than that determined by the plane frame model, 0.0209", because bending stiffness was considered in the latter.

A vertical unit load was placed on each panel point along the bottom truss to generate influence lines for axial forces in various truss elements and also for comparison with the results of the load tests. The influence lines successfully predict trends in the element forces, but the measured forces do not always correspond. Maximum forces from the passage of the 12-ton truck were 1 kip tension in vertical U_4L_4 , 6 kips compression in compressive diagonal U_3L_2 , and 4 kips tension in tensile diagonals U_1L_2 and U_3L_4 . The average displacement for the east and west truss due to the 12 ton load was 0.27".

A typical nineteenth century design live load of 80 lbs/ft² was placed over half the span and the full span of the Harshman Bridge to check performance under these conditions. Maximum stresses when the load was placed over the entire span were all within or below the acceptable range of allowable bending stress in pine and wrought iron. With the live load over half the span, looseness was predicted in one compression diagonal. The minimum loads to cause looseness in the compression diagonals adjacent to the midspan were predicted to be a uniform live load of 57 lbs/ft² over half the span or a concentrated vertical load of 9.5 kips at node L_5 . Stresses were checked in the girders with and without the retrofitted steel beams. The steel beams increase the maximum shear stress by 8 percent, but reduce the normal stress in the girders by 85 percent.

Tightening of the truss with dead load active was also modeled. Tightening caused an increase of tension in the rods, a decrease in the compressive forces in the wood diagonals, and a decrease of tension in the verticals. Members in panels adjacent to the tightened rod experienced significantly smaller forces, and the tightening caused very small displacements.

A creep analysis was performed using the plane frame model and assuming a strain due to creep of ± 0.0005 . For a truly accurate calculation of stresses and displacements due to creep, viscoelastic analyses would be required, but this approximate analysis shows the general redistribution of member forces due to creep of the wood.

The Long, Howe, and Pratt prestressed trusses were in use at the time of the Childs truss patent. The novelty of the Childs truss in comparison with these other forms was that it did not need to be prestressed in order for both its diagonals to be active.

Early Wood Truss Bridges and the Horace Childs Patent of August 1846

Timothy Palmer built the first covered bridge in the United States in 1805 in Philadelphia over the Schuylkill River. Desiring to prevent the weathering common to wooden truss bridges at the time, Palmer added a roof and exterior walls to his arch truss to dramatically increase its life.¹⁹ Other early covered bridge builders were Theodore Burr, Lewis Wernwag, and Ithiel Town. Burr employed the kingpost truss and combined it with an arch for his patent of April 1817.²⁰ Lewis Wernwag built his Colossus Bridge over the Schuylkill River in 1812. It was constructed of five parallel arched trusses, and spanned over 340'.²¹ Ithiel Town received a patent for his lattice truss design in January of 1820. With its many over-lapping wood planks and drilled connections at each intersection with hardwood pegs (trunnels), Town's design was very rigid.²²

In 1826, C. Navier published a set of lectures that included analysis and design techniques for simple trusses. Navier gave solutions for finding forces in a simple triangular truss, and a method for finding forces in simple statically indeterminate trusses. He also introduced the concept of analyzing a parallel chord truss as a beam, where the stiffness of the truss is proportional to the chord areas times the square of the distance between the chords. Navier's developments were used by American truss bridge designers in the 1830s and 1840s.²³

Stephen Long received a patent for a truss in March 1830. Long introduced prestressing to wooden truss bridges and used Navier's developments to design trusses possessing a known flexural strength.²⁴ His design consisted of two parallel chords divided into panels, with each panel consisting of a main diagonal brace and a counter brace, which were both placed into compression by wedges driven between the counter and the chords. Prestressing avoided the need for tension connections in the braces, allowed the diagonals to add to the stiffness of the truss, permitted some shrinkage in the wood, and provided camber to the bridge.²⁵

William Howe's second truss bridge patent, granted in August 1840, offered a new method of prestressing. Howe replaced the vertical posts with iron rods that could be tightened.²⁶ His patented double-intersection form was later revised to have a single-intersection in the diagonal members. The truss was prestressed by tightening nuts at the top chord, making the Howe truss easier to construct than the Long. Because of this ease of construction, the uniformity in member

¹⁹ *American Wooden Bridges*, (New York: American Society of Civil Engineers Historical Publication, 1976).

²⁰ *Engineering News and American Contract Journal* (October 28, 1882), p. 371

²¹ *American Wooden Bridges*.

²² The influence of the Town lattice truss design in both the United States and Europe has been examined in G.K. Dreicer, "The Long Span. Intercultural Exchange in Building Technology," (Ph.D. diss., Cornell University, Ithaca, New York, 1993).

²³ D.A. Gasparini and C. Provost, "Early Nineteenth Century Developments in Truss Design in Britain, France, and the United States," *Journal of the Construction History Society* 5 (1989): p. 22.

²⁴ D.A. Gasparini and C. Simmons, "American Truss Bridge Connections in the 19th Century, Part I: 1829-1850," *American Society of Civil Engineers Journal of Performance of Constructed Facilities* II, no. 3 (August 1997): p. 119.

²⁵ Gasparini and Provost, "Early Nineteenth Century Developments in Truss Design," p. 28.

²⁶ *Engineering News and American Contract Journal* (November 11, 1882), p. 394.

sizes, and ability to easily replace and repair parts of the truss, railroad companies extensively utilized Howe's design.²⁷

In April 1844, Thomas and Caleb Pratt received a patent for their truss. Like Howe, they introduced threaded iron rods into their truss for use as prestressing elements. These iron main diagonals and counter diagonals extended through the top and bottom chords, where they were fastened with nuts and could be tightened. The important difference between the Pratt truss and the Howe truss was that the system of two iron tension elements per panel allows for greater control of the camber in the bridge and the tensile iron diagonals make the Pratt form more efficient.²⁸ However, the inclined tension elements were more difficult to pretension and caused compression perpendicular to the grain of the wood chords.

Horace Childs, a nephew of S.H. Long, had first-hand experience with construction of the Long truss.²⁹ Childs was a sub-agent for the Long truss patent, which means he had acquired the right to use the Long truss for any bridge he might erect. He is known to have supervised the construction of at least one Long truss bridge—a two-span, 340' long structure crossing the Connecticut River at Haverhill, New Hampshire.³⁰

Horace Childs conceived his own truss form and received a patent on August 12, 1846 (Figure 1). Childs hoped to correct certain "defects" in wooden truss bridges. Childs' main concerns with truss bridges such as Long's were the high levels of tensile stress in the vertical posts and the lack of positive connections between the diagonal members and the chords and posts.³¹

²⁷ Gasparini and Simmons, "American Truss Bridges in the 19th Century. Part I," p. 123.

²⁸ *Engineering News and American Contract Journal* (December 2, 1882), p. 418;

Gasparini and Simmons, "American Truss Bridge Connections in the 19th Century. Part I," p. 126.

²⁹ Geneological Records, New Hampshire Antiquarian Society, 300 Main Street, Hopkinton, NH.

³⁰ S.H. Long, *Description of Col. Long's Bridges together with a Series of Directions to Bridge Builders* (Concord, NH: Start and Universalist Press, 1836), pp. 47-48.

³¹ H. Childs, Patent No. 4693, August 12, 1846.

H Childs.
Truss Bridge.
N^o 4,693. *Patented Aug. 12, 1846.*

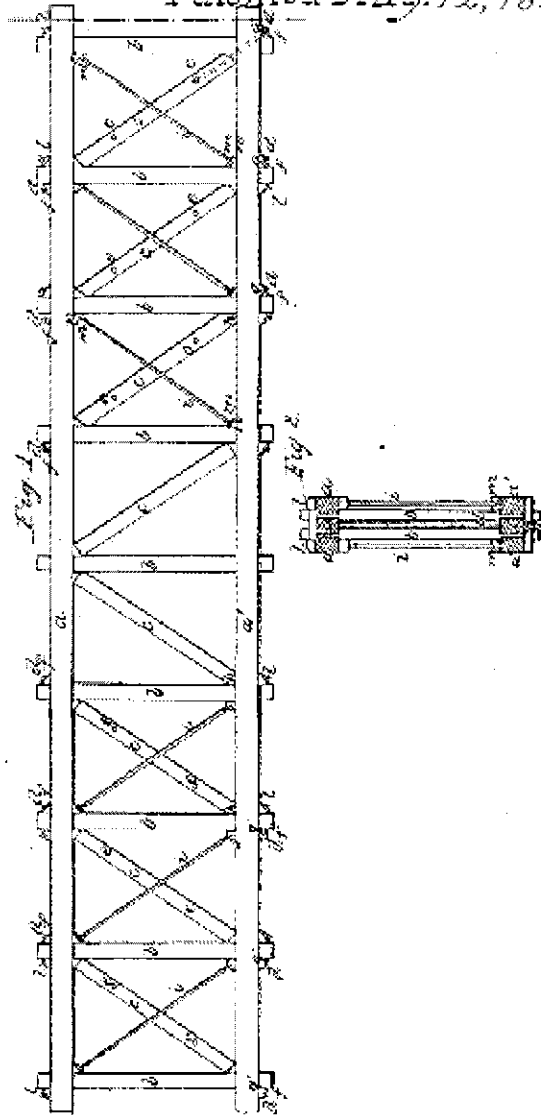

Figure 1. Childs truss, Patent No. 4693, August 12, 1846

Childs made only two claims in his patent, both of which involved new connection details for the diagonal members. The first idea was the addition of nuts and “shoe pieces” to the suspension rods at the underside of the top chord and the upper side of the bottom chord. This modification

was intended to secure the connection between the posts and the chords. Secondly, Childs suggested adding a mechanical connection to the compressive diagonals by way of a screw bolt, secured by a pin through the diagonals and the eye of the bolt, and extending the screw bolt through the chord and post where it could be secured on the outside with a nut, as shown in Figure 2.³² Both of these features are described in the patent but they are barely visible in Childs' patent drawing.

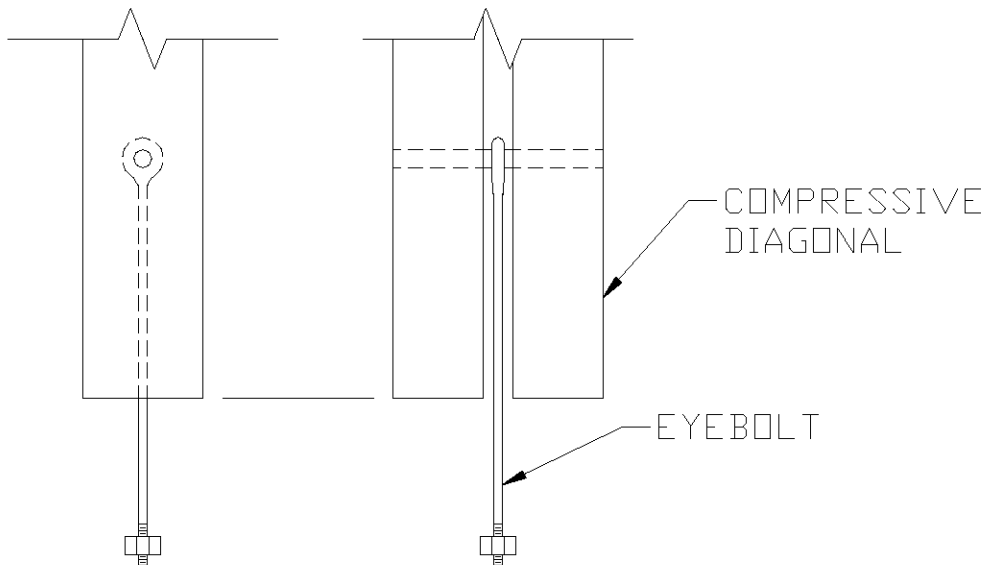

Figure 2. Detail of eyebolt connection detail patented by Childs

The motive behind Childs' decision to patent his diagonal brace connections is unknown, but it may have been intended to make construction of the bridge truss easier by providing threaded bolt connections for both diagonals, unlike the simple bearing connections of a Long truss. Aside from constructability issues, one definite advantage of Childs' truss design over that of Long's was that the tensile forces in the vertical posts were less with the counter diagonals in tension. The transfer of large tensile forces into the verticals in a Long truss can lead to shear failures in the wood "shoulders" of the verticals, such as the Eldean Bridge (see HAER No. OH-122).

A peculiar feature of Childs' design is that the center panels of the truss lack mechanical connections in the compressive diagonals and suspension/counter braces. The absence of these can lead to the central diagonals becoming loose under heavy live loads near mid span. Childs' reasons for this feature are unknown (they are never mentioned in the patent), but perhaps he saw it as a way to simplify the bridge or make it more economical.

³² Childs, Patent No. 4693, August 12, 1846.

Assuming that the eyebar detail shown in Figure 2 could not develop significant tension, the Childs truss could not be prestressed in the same way as the Long, Howe and Pratt forms. The primary effect of tightening the nuts on the counters was to provide camber and decrease the dead load compressive forces in the main diagonals.

Everett Sherman and the Harshman Bridge

Everett Sherman built the Chambers Road Bridge over Big Walnut Creek in Delaware County, Ohio, in 1883 (see Figure 3). The bridge is comprised of eight panels, and it has wooden compression and wrought iron tension diagonals, except in the innermost panels, which have only wood compression members. The top chords have simple butt joints, the wood diagonals rely on compression for their connections, and the tension rods are secured with nuts only on the outside of the chords.

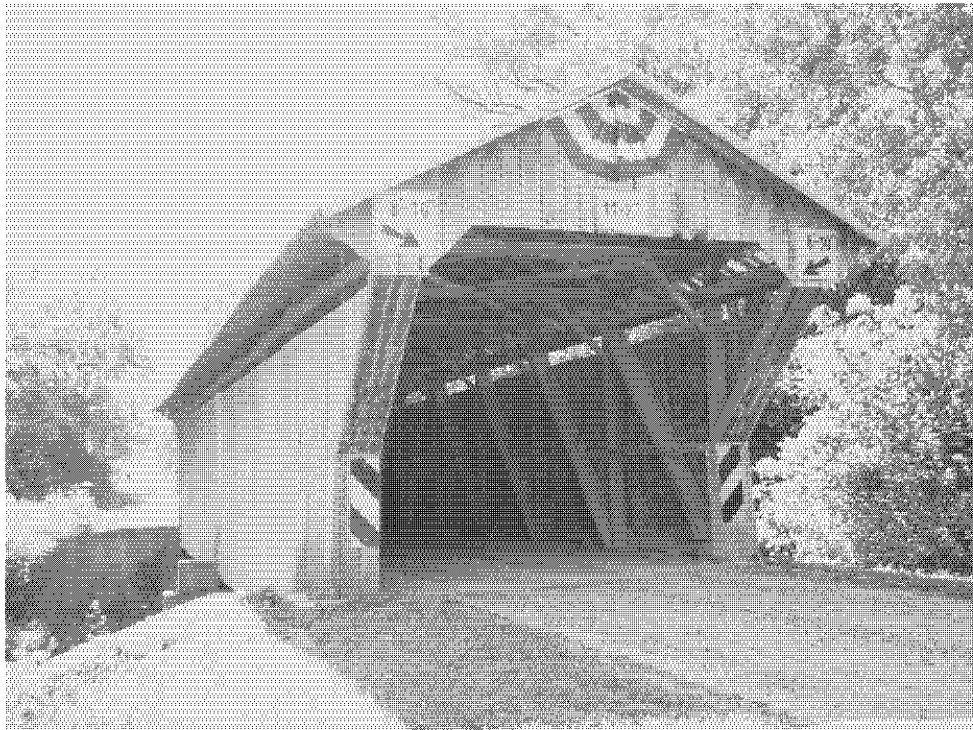

Figure 3. Chambers Road Bridge, built by Everett Sherman in 1883

There is evidence of many repairs to the Chambers Road Bridge, likely in response to deterioration of the bridge. Some of the butt joints in the top chord have shifted (perhaps when the midspan pier was added), making them ineffective, and they were haphazardly nailed back together at an unknown time (Figure 4). In places, pieces of wood have been wedged in between the top of the compressive diagonals and the intersection of the verticals and chords (Figure 5), most likely to introduce some compression to the members and help them stay in place. There are two vertical steel rods on either side of the vertical posts (Figure 5). These may have been part of the original design or a retrofit. One of the vertical rods passes through the bottom chord

and carries a section of the girder, thus it transfers part of the floor loads directly to the top nodes. The other vertical rod may have been intended to decrease or eliminate any potential tensile force in the vertical. More significantly, a central pier and longitudinal steel beams were added to the Chambers Road Bridge. These retrofits changed or eliminated the structural role of the trusses.

The Chambers Road Bridge does not have two details of the Childs truss patent, that is, two nuts at each end of the diagonal rods and the eyebolts. It resembles the Childs truss in the use of a combination of wood and iron diagonals and the omission of iron diagonals in the panels adjacent to the midspan.



Figure 4. Chambers Road Bridge, detail of butt joint



Figure 5. Chambers Road Bridge, detail of connection

In the late 1880s, Sherman moved to Preble County, Ohio, because of an invitation from county engineer Robert Eaton Lowery to rebuild county bridges destroyed by a storm in May 1887. Between 1887 and 1895, Sherman constructed fifteen bridges similar in design to the Chambers Road Bridge and echoing the form of the Childs truss.³³

The Harshman Bridge

Sherman constructed the Harshman Bridge over Four Mile Creek in Preble County in 1894. Spanning 109', this bridge is of the same basic form as Sherman's others in Preble County. It is a skew bridge, with dummy panels added to provide square end portals, as shown in Figure 6. The bridge is about 18' tall from the ground to peak of the roof and is only wide enough for one vehicle. The wood species used on the Harshman Bridge have not been determined, but it is likely that the superstructure is pine and the floor is oak. The posted load limit is 12 tons.

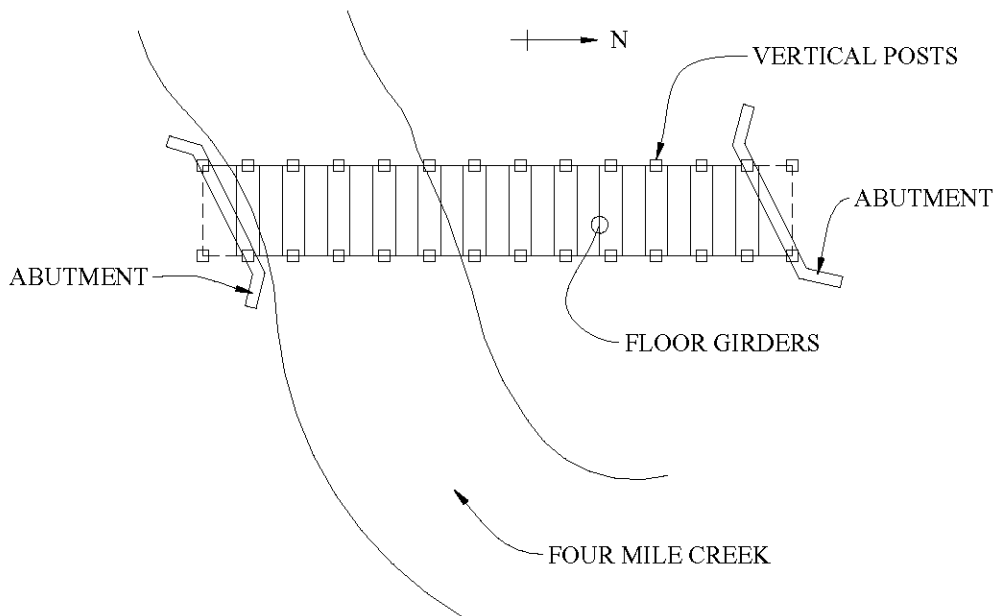

Figure 6. Skew of Harshman Bridge relative to Four Mile Creek

Like the Chambers Road Bridge, the Harshman bridge consists of wooden compression members sans positive connections; iron diagonals secured with nuts only on the outside of the chords; butt joints along the top chord; and both bolt and trunnel connections along the bottom chord (Figure 7). The spacing of the girders is approximately half the panel width. They are attached by U-bolts (Figures 8, 9) to the bottom chord. The connection on the left of Figure 8, made of

³³ Wood, *The Covered Bridges of Ohio*, pp. 29-30

wood blocks and square nuts, is probably an original detail, while the right connection is a retrofit.

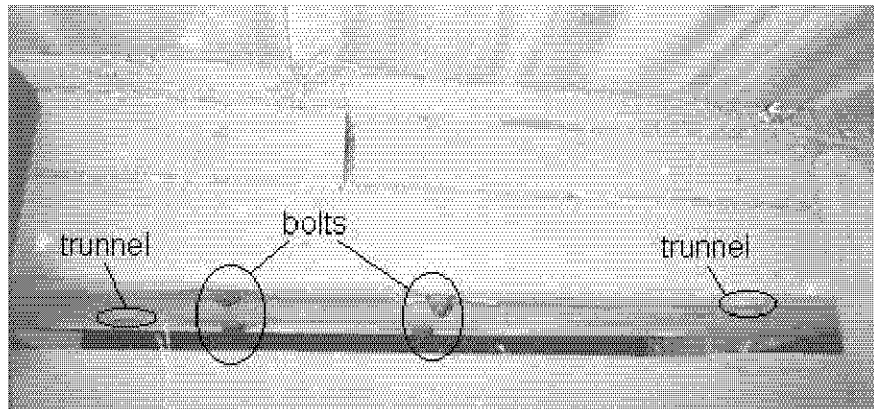

Figure 7. Bottom chord splice detail



Figure 8. Detail of U-bolt connection of girders to the bottom chord (older connection on left)

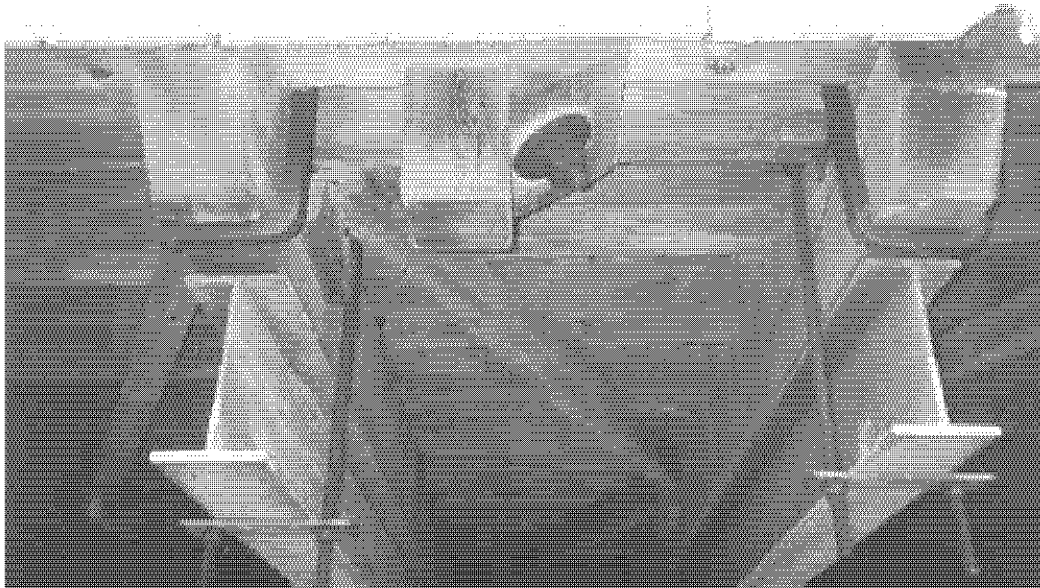

Figure 9. Underside of U-bolt connection showing the retrofitted steel beams

The framing provides lateral stiffness (shown in Figure 10), which exists at every panel point.

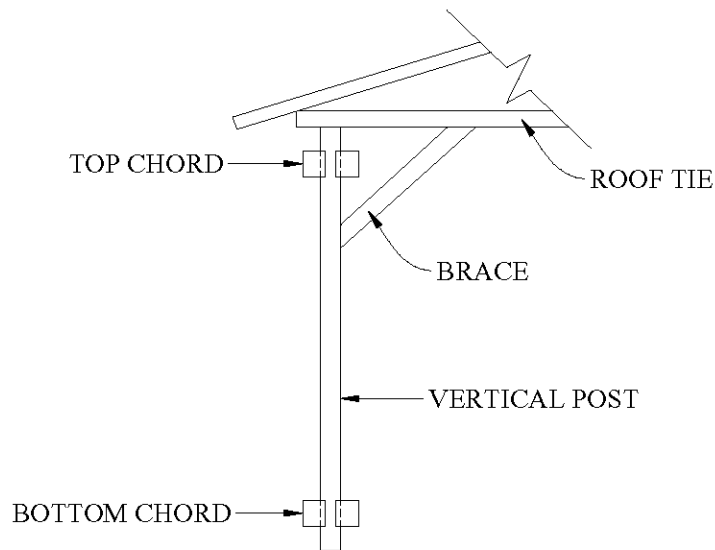

Figure 10. Lateral bracing system

One interesting feature of the bridge is the sizing of the wooden compressive diagonals and iron tensile diagonals. Starting at the outermost panel and working towards the center, each panel contains a compressive diagonal of slightly smaller thickness, varying from 7.5" to 2.5" at the center panel. The suspension rods vary similarly, from 1.25" to 1" closest to the center.

Despite its age, the Harshman Bridge appears to be in excellent condition and has only seen some minor repairs. The approaches are well graded. Insect damage (a hole approximately 6" long and 1.5" wide) exists on the east end of the northernmost girder. Steel beams have been attached to the bottom of the girders. These help the wood girders in bending only. The compression diagonal in the south panel adjacent to the centerline of the east truss is loose and out of plane. Like the Chambers Road Bridge, the chords are only connected with butt joints, which appear to be in good condition. Bolts and trunnels connect the bottom chords. The roof of the bridge was not inspected.

Probably the most significant modifications to the Harshman Bridge were done near the supports. Short lengths of the bottom chords at each end of the bridge have been replaced and spliced with steel plates. The bottom halves of the vertical posts that connect into these chords have also been replaced. Concrete bearing pads, 5" thick, have been added at the four support points. The piers have been treated with unite, likely to protect against further freeze-thaw damage in the stone. No evidence of scouring is evident on the piers, and under normal flow conditions, the northern pier is in dry conditions.

There were many differences between Sherman's design of the Harshman Bridge and Childs' patent truss. Sherman used a single compressive diagonal and a single rod passing through a hole in the wood, whereas Childs' patent called for pairs of iron and wood pieces for the diagonals. Another important difference is the absence of the eyebolt connection in the compressive diagonals and the extra nuts on the tensile rods, both of the patented features of Childs' design. Therefore it may more precisely be said that the Harshman Bridge is of a design particular to Everett Sherman; it only resembles the patented Childs truss in its use of wrought iron rods for the tension diagonals and wood for the compressive diagonals. Simmons hypothesizes that Sherman saw an 1882 *Engineering News* article on expired bridge truss patents and that he adapted the Childs truss for all his designs, beginning with the Chambers Road Bridge.³⁴

There are interesting questions and issues related to the design, construction, and behavior of the Harshman Bridge. The bridge was designed in 1894, when statically determinate analyses were well-known and statically determinate truss forms dominated. How did Sherman analyze the bridge, and proportion the size of the diagonals? Why did Sherman use closely-spaced girders, which produce bending in the lower chords? How were the nuts tightened? As constructed, how did the bridge carry dead loads and live loads and what were the effects of wood creep on the structural behavior? To study these issues, the bridge was tested and analyzed as follows.

Testing of the Harshman Bridge

The Harshman Bridge was instrumented and tests were performed to determine its structural behavior. Strain gauges and strain transducers were placed on the southern half of the west truss.

³⁴ David A. Simmons, "Unique Covered Bridges in Delaware County" *Ohio County Engineering News* (Spring 1991), p. 10; *Engineering News and American Contract Journal* (December 16, 1882), p. 433.

Five strain gauges were used, one on each tension rod, and eight strain transducers were used on wooden members, six on compression diagonals and two on a vertical post. The instruments were positioned as shown in Figure 11.

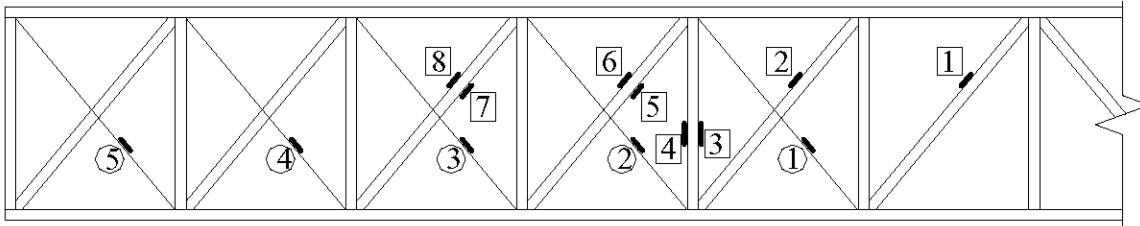

- = ELECTRICAL RESISTANCE STRAIN GAUGE
- = STRAIN TRANSDUCER

Figure 11. Placement of instruments

Figure 12 shows a typical strain transducer attached to the timber diagonal with two 1/4" lag screws. In addition, displacement transducers (DCDTs) were placed at the midspans of both trusses to measure the vertical deflection of the bridge during tests (Figure 13).

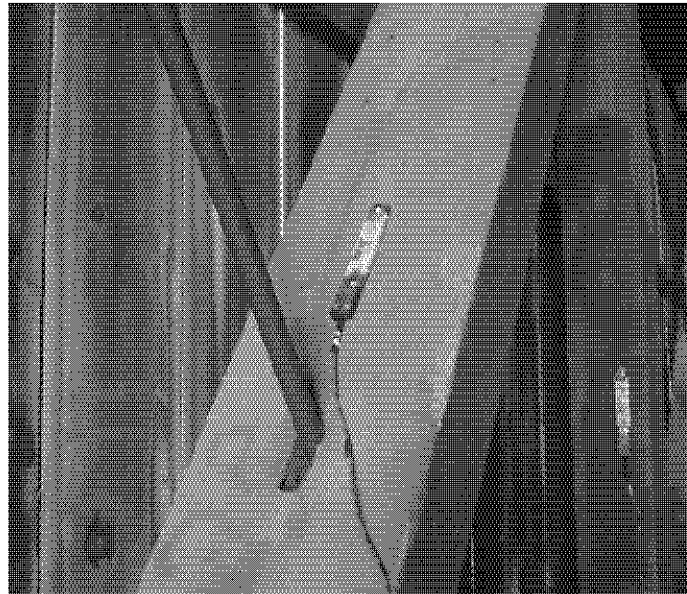

Figure 12. Strain transducer on compression diagonal

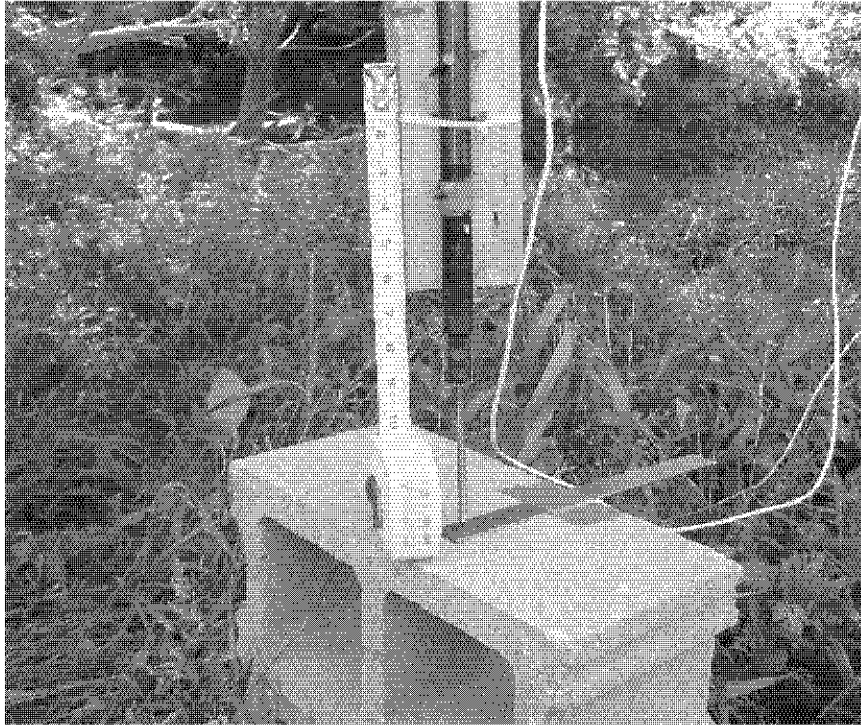

Figure 13. Displacement transducers to measure vertical deflection

The first test performed on the bridge consisted of loosening and tightening the top nut of the southernmost tension diagonal on the west truss. Figure 14 shows that the axial force in the bar reached a maximum value over 2300 pounds. In a 2002 study of the Pine Bluff Bridge (see HAER No. IN-103), a Howe truss in Putnam County, Indiana, a similar experiment (with the same person tightening the nut using the same wrench) yielded a maximum force of over 6000 pounds. Results of such experiments are very dependent on the amount of rust present, the pitch of the treads, and probably the diameter of the rod, but they are nonetheless useful for providing data on the tension that can be induced by manually tightening a nut.

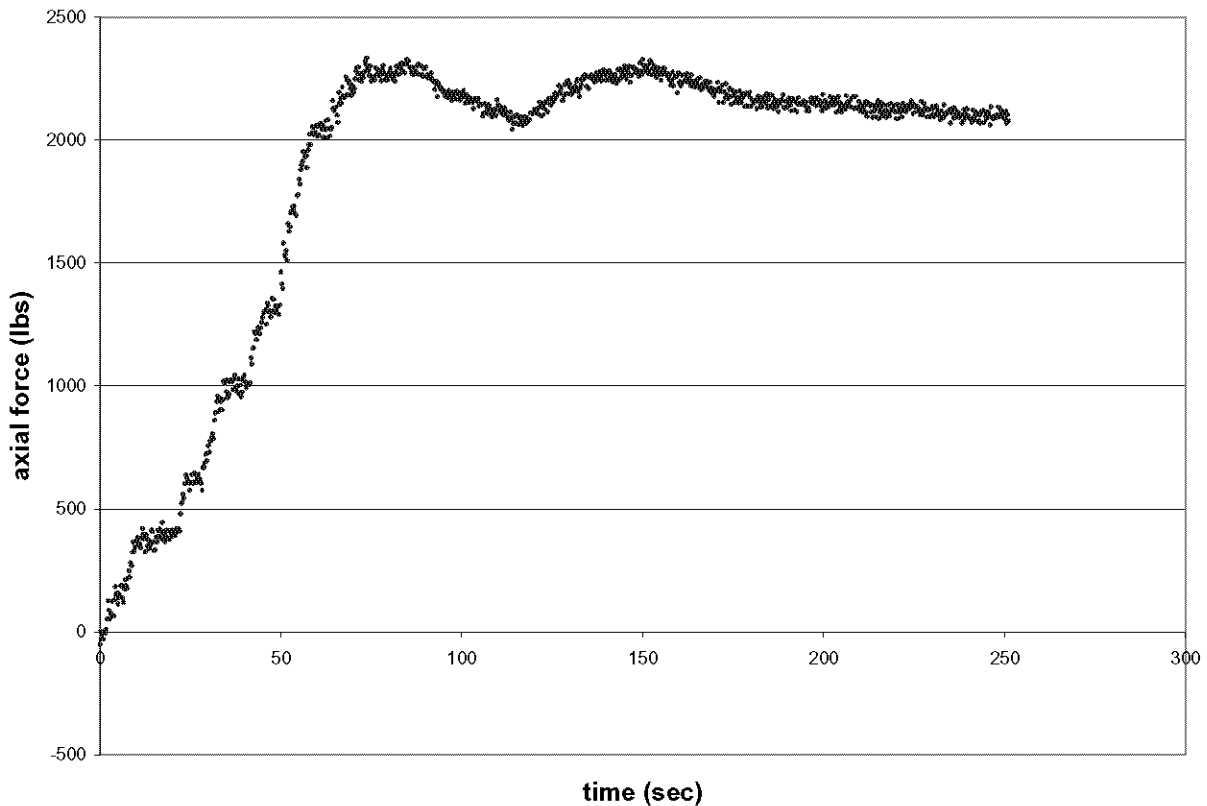

Figure 14. Force in tightened rod

The Harshman Bridge was next tested by traversing the span with a 12-ton truck provided by the Preble County Highway Department. Three runs were made, the first and third time stopping at the locations shown in Figure 15, and the second time driving through nonstop. Data from the tests are discussed in conjunction with the analytical predictions in the following sections.

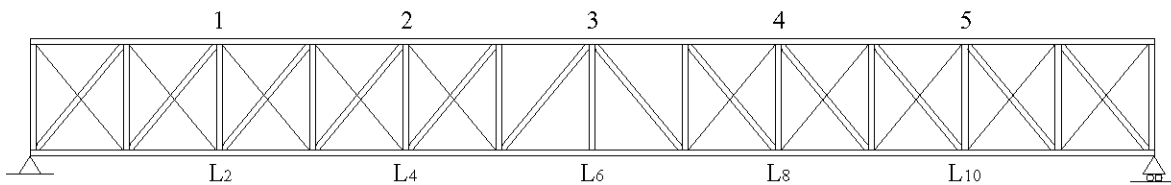

Figure 15. Truck stops (west truss) for Runs 1 and 3

Modeling and Analyses of the Harshman Bridge

A necessary first step was to calculate the dead weight of the bridge and to compute geometric properties of the cross-sections. The floor was assumed to be oak with a unit weight of 44 lbs/ft³. All other wood components were assumed to be yellow pine, with a unit weight of 38 lb/ft³. Table 1 lists contributions of the trusses, siding, deck, and roof to the total weight, which was estimated to be 95,400 lbs. This figure was increased by 10 percent to account for uncertainties and miscellaneous connection parts. Therefore a total dead weight of 104,900 lbs was used for analysis.

It was assumed that all wood members have the same modulus of elasticity, E , equal to 1,200,000 lbs/in². The modulus of the iron was assumed to be 28,000,000 lbs/in². Table 2 summarizes element areas, moments of inertia, section moduli, and axial stiffnesses, EA/L . The axial stiffnesses of the compression wood diagonals are approximately three times the axial stiffnesses of the corresponding tension iron diagonals.

Table 2. Member properties

Element	Length	Area (A)	Moment of inertia (I)	Section modulus (S)	Elastic modulus (E)	Axial stiffness (k=EA/L)
	(in)	(in ²)	(in ⁴)	(in ³)	(psi)	(lbs/in)
Top chord	97.86	126.0	651	165.33	1,200,000	1545100
Bottom chord	97.86	192.0	2304	384.00	1,200,000	2354400
Verticals	146.22	47.27	186.2	54.17	1,200,000	382500
Compressive diagonals U ₀ L ₀ , U ₁₁ L ₁₂	159.75	93.0	465.5	120.13	1,200,000	628200
U ₂ L ₁ , U ₁₀ L ₁₁	159.75	81.0	307.5	91.11	1,200,000	547100
U ₃ L ₂ , U ₉ L ₁₀	159.75	69.0	190.1	66.12	1,200,000	466100
U ₈ L ₉	159.75	60.0	125.0	50.00	1,200,000	405300
U ₄ L ₃	159.75	57.0	107.2	45.14	1,200,000	385000
U ₇ L ₆	159.75	48.0	64.00	32.00	1,200,000	324200
U ₅ L ₄	159.75	45.0	52.73	28.12	1,200,000	304000
U ₆ L ₇	159.75	36.0	27.00	18.00	1,200,000	243200
U ₆ L ₅	159.75	33.0	20.80	15.13	1,200,000	222900
Tension rods U ₀ L ₁ , U ₁ L ₂ , U ₁₁ L ₁₀ , U ₁₂ L ₁₁	202.77	1.227	0.120	0.192	28,000,000	193400
U ₂ L ₃ , U ₃ L ₄ , U ₉ L ₈ , U ₁₀ L ₉	202.77	0.994	0.0786	0.140	28,000,000	156700
U ₄ L ₅ , U ₈ L ₇	202.77	0.785	0.0491	0.0982	28,000,000	123700

Two mathematical models of the Harshman Bridge were defined. One was a plane truss model that was used for approximate manual analyses. The other was a plane frame model for computer structural analyses. The plane truss model is shown in Figure 16. The model assumes symmetry about the midspan, therefore it was used only for symmetric dead and live loads. The model is statically indeterminate to the fifth degree. Sherman almost certainly used some approximate manual analysis procedure to estimate member forces. Here it was assumed that the vertical component of the force in a diagonal was equal to the total shear in the panel times the ratio of the axial stiffness of the diagonal to the sum of the axial stiffnesses of the two diagonals.

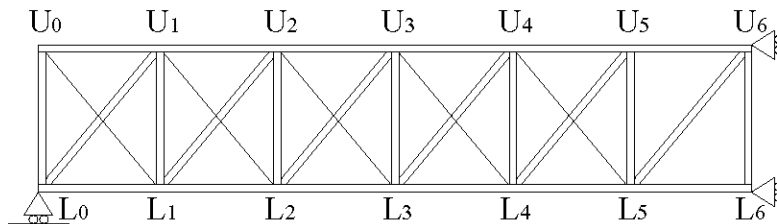

Figure 16. Plane truss model used for manual analyses

The plane frame model is shown in Figure 17. Moment connections were assumed for all members. It was assumed that all girders were supported at the quarter points of the panels, therefore nodes were defined at those points.

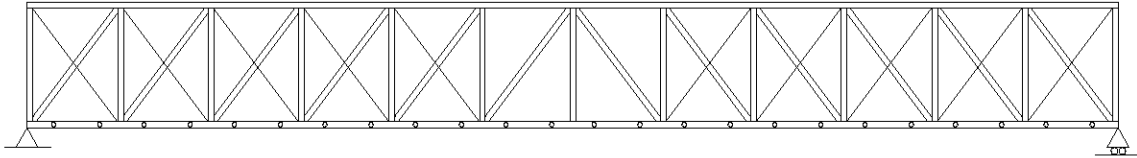

Figure 17. Plane frame model used for computer analyses

Dead Load Analyses and Behavior

To compute effects of self-weight, uniformly distributed vertical loads were applied to each model. For the plane frame model, the floor dead loads were applied at the quarter-points, where the girders are supported. Table 3 compares member axial forces computed using the approximate manual analysis with corresponding forces calculated by computer analysis (using MASTAN2).

Table 3. Results of dead load analyses

Member	Manually calculated force	MASTAN2 calculated force	Difference
	(kips)	(kips)	(kips)
Top chord			
U ₀ U ₁	-3.291	-3.794	0.503
U ₁ U ₂	-18.957	-21.179	2.222
U ₂ U ₃	-31.257	-32.493	1.236
U ₃ U ₄	-41.021	-41.843	0.822
U ₄ U ₅	-47.533	-47.984	0.451
U ₅ U ₆	-50.772	-50.879	0.107
Bottom chord			
L ₀ L ₁	12.666	12.3	0.366
L ₁ L ₂	26.013	24	2.013
L ₂ L ₃	36.923	35.868	1.055
L ₃ L ₄	44.566	43.889	0.677
L ₄ L ₅	49.659	49.373	0.286
L ₅ L ₆	52.223	52.183	0.04
Verticals			
U ₀ L ₀	-6.291	-7.005	0.714
U ₁ L ₁	13.36	9.239	4.121
U ₂ L ₂	10.548	5.645	4.903
U ₃ L ₃	7.885	4.918	2.967
U ₄ L ₄	5.2	3.492	1.708
U ₅ L ₅	3.612	2.991	0.621
U ₆ L ₆	1.55	2.775	1.225
Compression diagonals			
U ₁ L ₀	-23.009	-22.093	0.916
U ₂ L ₁	-18.268	-14.284	3.984
U ₃ L ₂	-14.37	-12.165	2.205
U ₄ L ₃	-9.808	-8.385	1.423
U ₅ L ₄	-5.884	-5.196	0.688
U ₆ L ₅	-2.635	-2.368	0.267
Tension rods			
U ₀ L ₁	5.978	6.785	0.807
U ₁ L ₂	5.449	9.245	3.796
U ₂ L ₃	4.076	6.077	2.001
U ₃ L ₄	3.368	4.691	1.323
U ₄ L ₅	2.022	2.682	0.66

There was excellent agreement in chord forces and very good agreement in the diagonal forces. The forces in the verticals predicted by the two models show greater percent differences. In general, the close agreement between forces computed using the two models indicates that the

bridge acts primarily as a truss and that approximate manual analyses may be adequate for design.

Results of the computer analysis show the tension rods carry a greater percentage of the shear force in each panel than assumed in the manual analysis. Table 4 shows the ratio of the computer-calculated forces versus that used in the manual calculations. The closest correspondence between the ratios can be seen in the first ($U_0U_1L_1L_0$) panel of the truss, where the outermost diagonal sees a large force from the support.

Table 4. Stiffness and force ratios for diagonal members

Compression diagonal	Tension rod	Ratio of K values = Assumed ratio of manually calculated forces	Ratio of MASTAN2 calculated forces
U_1L_0	U_0L_1	3.85	3.26
U_2L_1	U_1L_2	3.35	1.55
U_3L_2	U_2L_3	3.52	2.00
U_4L_3	U_3L_4	2.91	1.79
U_5L_4	U_4L_5	2.91	1.94

As seen in Table 3, dead load forces in the diagonal members decrease towards the midspan of the truss, which forms the basis for Sherman's decision to decrease the size of the diagonal members. Tables 5 and 6 show dead load axial stresses in the diagonals. The magnitudes are comparable along the span, which attests to the rationality of Sherman's decrease in the member sizes towards the midspan.

Table 5. Axial stresses in the compression diagonals

Compression diagonal	Cross-section area	Manually calculated force	Axial stress	MASTAN2 calculated force	Axial stress
	(sq. in.)	(kips)	(ksi)	(kips)	(ksi)
U_1L_0	93.0	-23.009	0.247	-22.093	0.238
U_2L_1	81.0	-18.268	0.226	-14.284	0.176
U_3L_2	69.0	-14.370	0.208	-12.165	0.176
U_4L_3	57.0	-9.808	0.172	-8.385	0.147
U_5L_4	45.0	-5.884	0.131	-5.196	0.115
U_6L_5	33.0	-2.635	0.080	-2.368	0.072

Table 6. Axial stresses in the tension rods

Tension Rod	Cross-section area	Manually calculated force	Axial stress	MASTAN2 calculated force	Axial stress
	(sq. in.)	(kips)	(ksi)	(kips)	(ksi)
U ₀ L ₁	1.227	5.978	4.872	6.785	5.530
U ₁ L ₂	1.227	5.449	4.441	9.245	7.535
U ₂ L ₃	0.994	4.076	4.101	6.077	6.114
U ₃ L ₄	0.994	3.368	3.388	4.691	4.719
U ₄ L ₅	0.785	2.022	2.576	2.682	3.417

For the plane frame model, the members have both axial forces and bending moments. Table 7 shows stresses from axial forces and maximum combined stresses from both axial forces and bending moments in four members. Bending moments contribute 10 to 40 percent to the combined maximum stresses. The maximum combined dead load stresses are greater in the compressive top chord than in the tensile bottom chord. The maximum combined dead load stresses are less than 500 lbs/in² in all cases.

The vertical dead load displacement at midspan for the truss model was also calculated manually (using the Principle of Virtual Forces). It was estimated to be 0.834". The midspan vertical displacement for the plane frame model was predicted to be 0.773". It was expected that the plane frame model should have smaller displacements because of the addition of the flexural stiffness of the members. For both models, the predicted displacements depend on the assumption of the modulus of elasticity, which is highly uncertain.

Table 7. Effect of combined stresses

Element	Cross-section area	Section modulus	MASTAN2 calculated force	MASTAN2 calculated moment	Axial stress	Combined stress	% Contribution from moment
	(sq. in.)	(cu. in.)	(kips)	(k-in)	(ksi)	(ksi)	
Vertical U ₀ L ₀	47.27	54.17	-7.005	5.259	0.148	0.245	39.6
Compression diagonal U ₁ L ₀	93	120.13	-22.093	9.667	0.238	0.318	25.3
Top chord U ₅ U ₆	126.0	165.3	-50.879	7.615	0.404	0.450	10.2
Bottom chord L ₅ L ₆	192.0	384.0	52.183	27.748	0.272	0.344	21.0

Live Load Analyses and Behavior

Four live load conditions were considered. The first was a unit vertical load at midspan, in order to compare predictions of the two models. The second was a moving vertical load in order to determine influence lines that may be compared with the data from the tests. The other two were uniformly distributed live loads of 80 lbs/ft² over the entire span and over half the span. These latter live load conditions were studied to estimate the maximum stresses in the members for a typical nineteenth century distributed live load.

Table 8 shows element axial forces for a unit vertical live load at midspan in the two models. As for the dead loads, the chord forces from the two models are in good agreement, whereas the forces in the vertical members have greater percentage differences.

Table 8. Results of live load analysis, 1 kip load at center of truss (negative value indicates compression)

Element	Manually calculated force	MASTAN2 calculated force	Difference
	(kips)	(kips)	(kips)
Top chord			
U ₀ U ₁	-0.068	-0.080	0.0122
U ₁ U ₂	-0.406	-0.453	0.047
U ₂ U ₃	-0.733	-0.767	0.034
U ₃ U ₄	-1.074	-1.102	0.028
U ₄ U ₅	-1.404	-1.441	0.037
U ₅ U ₆	-1.650	-1.668	0.018
Bottom chord			
L ₀ L ₁	0.262	0.249	0.013
L ₁ L ₂	0.583	0.536	0.047
L ₂ L ₃	0.915	0.881	0.034
L ₃ L ₄	1.234	1.203	0.031
L ₄ L ₅	1.564	1.539	0.025
L ₅ L ₆	1.978	1.934	0.044
Verticals			
U ₀ L ₀	-0.068	-0.121	0.053
U ₁ L ₁	0.282	0.184	0.098
U ₂ L ₂	0.274	0.149	0.125
U ₃ L ₃	0.261	0.161	0.1
U ₄ L ₄	0.244	0.138	0.106
U ₅ L ₅	0.374	0.316	0.058
U ₆ L ₆	0.500	0.840	0.34
Compression diagonals			
U ₁ L ₀	-0.476	-0.449	0.027
U ₂ L ₁	-0.461	-0.372	0.089
U ₃ L ₂	-0.466	-0.400	0.066
U ₄ L ₃	-0.446	-0.386	0.06
U ₅ L ₄	-0.446	-0.404	0.042
U ₆ L ₅	-0.599	-0.481	0.118
Tension rods			
U ₀ L ₁	0.123	0.144	0.021
U ₁ L ₂	0.138	0.224	0.086
U ₂ L ₃	0.133	0.194	0.061
U ₃ L ₄	0.153	0.204	0.051
U ₄ L ₅	0.153	0.226	0.073

Table 9 shows the assumed and computed (using MASTAN2) ratios of the axial forces in the compressive diagonals to the axial forces in the tension rods. The assumption that the shear in each panel was shared by the diagonal members in proportion to their axial stiffnesses overestimates the force taken by the compression diagonals.

Table 9. Load sharing in diagonal members from a 1 kip vertical load at midspan

Compression diagonal	Tension rod	Ratio of K values = Assumed ratio of manually calculated forces	Ratio of MASTAN2 calculated forces
U ₁ L ₀	U ₀ L ₁	3.85	3.12
U ₂ L ₁	U ₁ L ₂	3.35	1.66
U ₃ L ₂	U ₂ L ₃	3.52	2.06
U ₄ L ₃	U ₃ L ₄	2.91	1.89
U ₅ L ₄	U ₄ L ₅	2.91	1.79

Tables 10 and 11 show stresses from axial forces produced by the 1 kip vertical load at midspan. In order to assess the relative importance of live loads and dead loads, these stresses should be multiplied by a reasonable design concentrated live load, such as the current load limit of 12 kips (or 12 tons on the entire bridge).

Table 10. Axial stress in compression diagonals from a 1 kip vertical load at midspan

Compression diagonal	Cross-section area	Manually calculated force	Axial stress	MASTAN2 calculated force	Axial stress
	(sq. in.)	(kips)	(ksi)	(kips)	(ksi)
U ₁ L ₀	93.0	-0.476	0.00512	-0.449	0.00483
U ₂ L ₁	81.0	-0.461	0.00569	-0.372	0.00459
U ₃ L ₂	69.0	-0.466	0.00675	-0.400	0.00580
U ₄ L ₃	57.0	-0.446	0.00782	-0.386	0.00677
U ₅ L ₄	45.0	-0.446	0.00991	-0.404	0.00898
U ₆ L ₅	33.0	-0.599	0.01815	-0.481	0.01458

Table 11. Axial stress in tension rods from a 1 kip vertical load at midspan

Tension Rod	Cross-section area	Manually calculated force	Axial stress	MASTAN2 calculated force	Axial stress
	(sq. in.)	(kips)	(ksi)	(kips)	(ksi)
U ₀ L ₁	1.227	0.123	0.100	0.144	0.117
U ₁ L ₂	1.227	0.138	0.112	0.224	0.183
U ₂ L ₃	0.994	0.133	0.134	0.194	0.195
U ₃ L ₄	0.994	0.153	0.154	0.204	0.205
U ₄ L ₅	0.785	0.153	0.195	0.226	0.288

The effects of moments from the one kip live load on maximum stresses are given in Table 12. The four members see between a 20 to 60 percent increase in stress with the addition of the moments.

Table 12. Combined stress under the 1 kip at center live load condition

Element	Cross-section area (sq. in.)	Section modulus (cu. in.)	MASTAN2 calculated force (kips)	MASTAN2 calculated moment (k-in)	Axial stress (ksi)	Combined stress (ksi)	% Contribution from moment
Vertical U_0L_0	47.27	54.17	-0.121	0.0837	0.0026	0.0041	37.6
Compression diagonal U_1L_0	93	120.13	-0.449	0.150	0.0048	0.0061	20.5
Top chord U_5U_6	126.0	165.3	-1.668	1.214	0.0132	0.0206	35.7
Bottom chord L_5L_6	192.0	384.0	1.934	5.632	0.0101	0.0247	59.3

The midspan vertical displacement from the one kip load at midspan was found to be 0.0308” by the manual calculations and 0.0287” by the computer analysis. As before, the smaller value predicted by the MASTAN2 analysis results from consideration of the axial and flexural stiffness by the program as opposed to only considering the axial stiffness in the manual calculations.

Using the results of computer analyses for the 1 kip load traversing the bottom chord, influence lines were plotted for vertical displacements at two nodes and for axial forces in key members of the bridge. Figure 18 shows vertical displacements at two nodes as a function of position of the unit load.

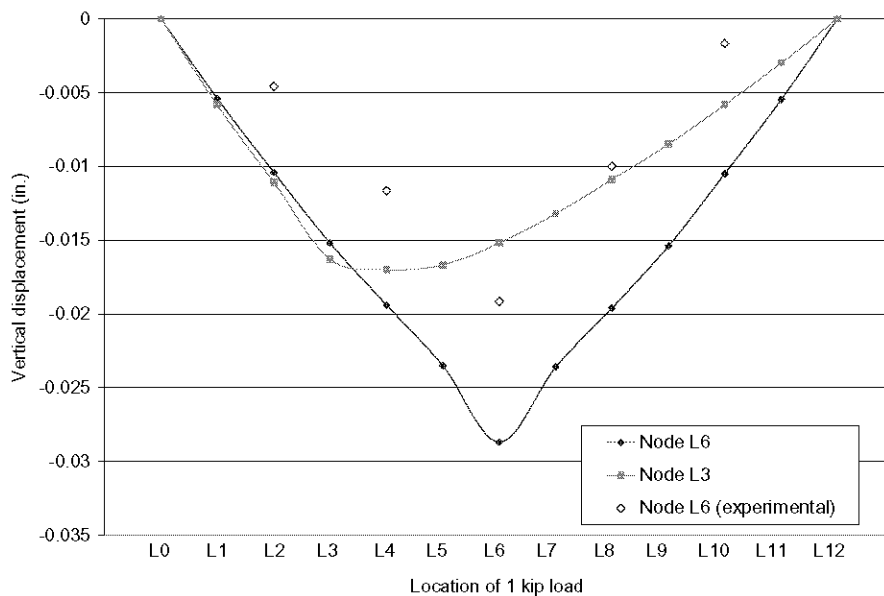

Figure 18. Influence lines for the vertical displacements of two nodes

Figures 19 through 23 show analytical influence lines for axial forces in nine truss members.

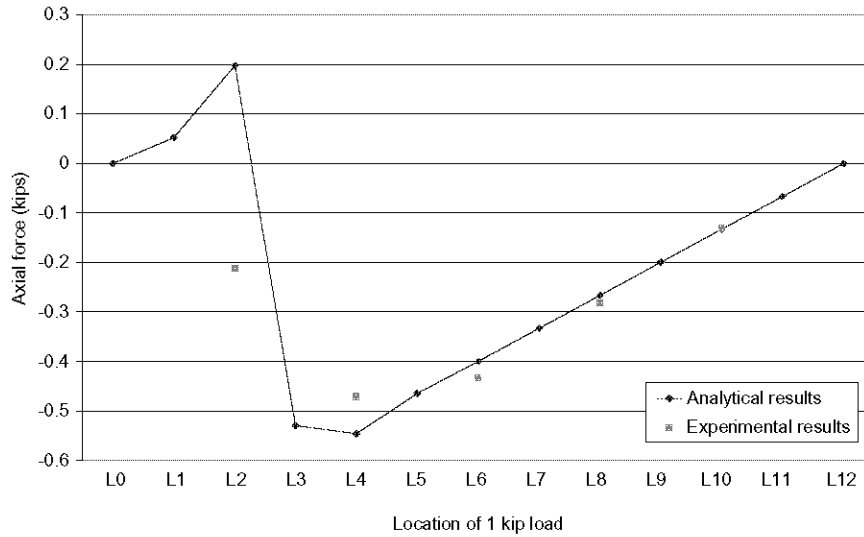

Figure 19. Influence line for compression diagonal U₃L₂

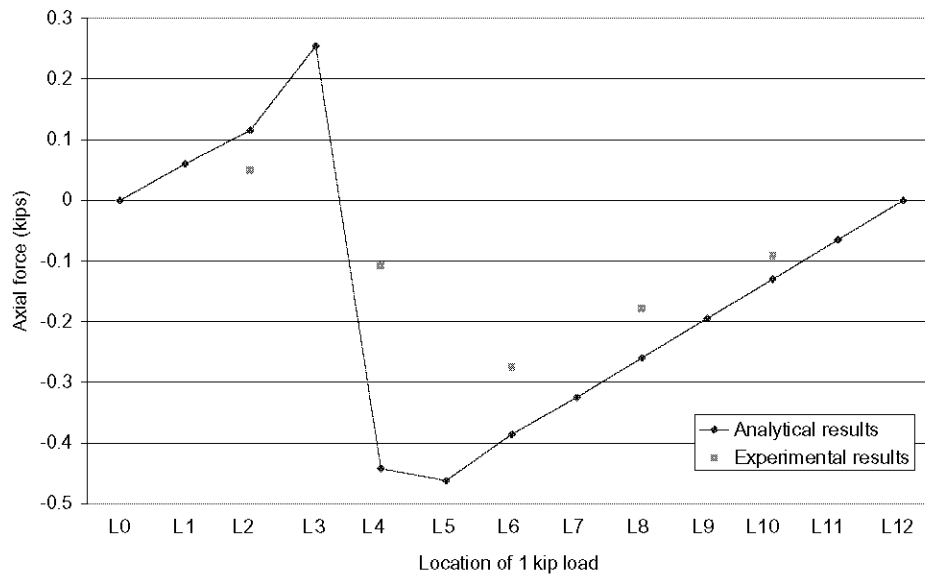

Figure 20. Influence line for compression diagonal U₄L₃

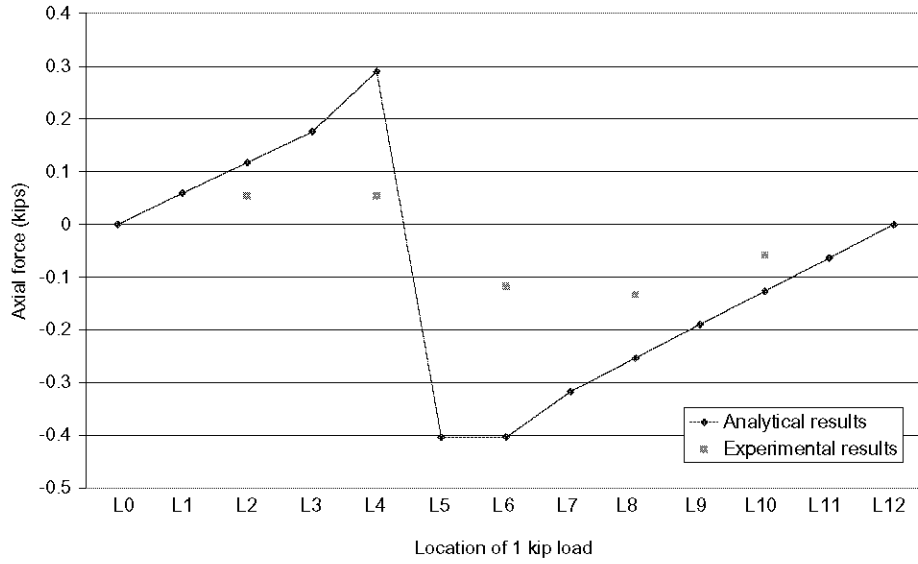

Figure 21. Influence line for compression diagonal U₅L₄

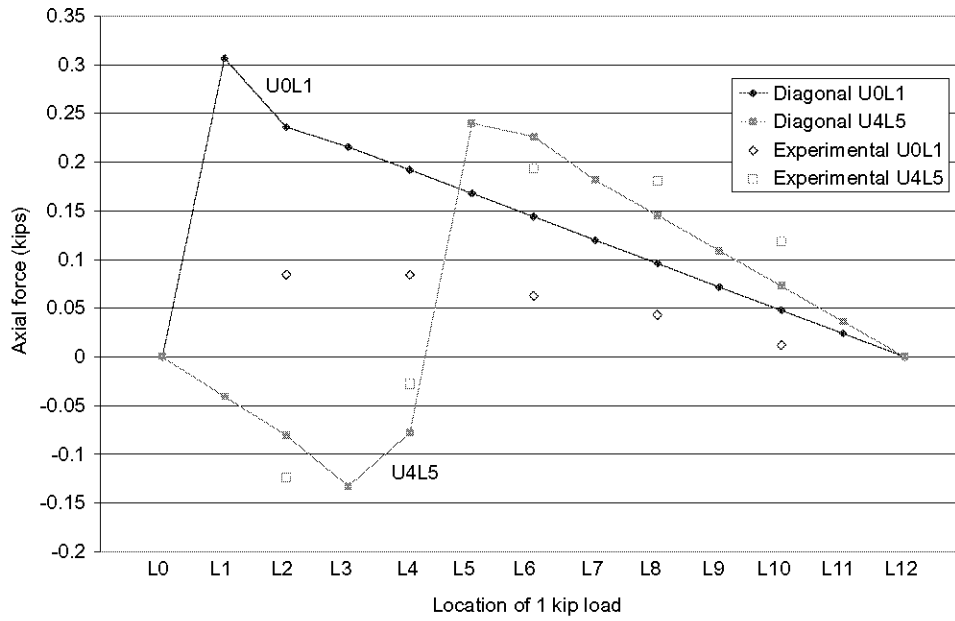

Figure 22. Influence lines for tension rods U₀L₁ and U₄L₅

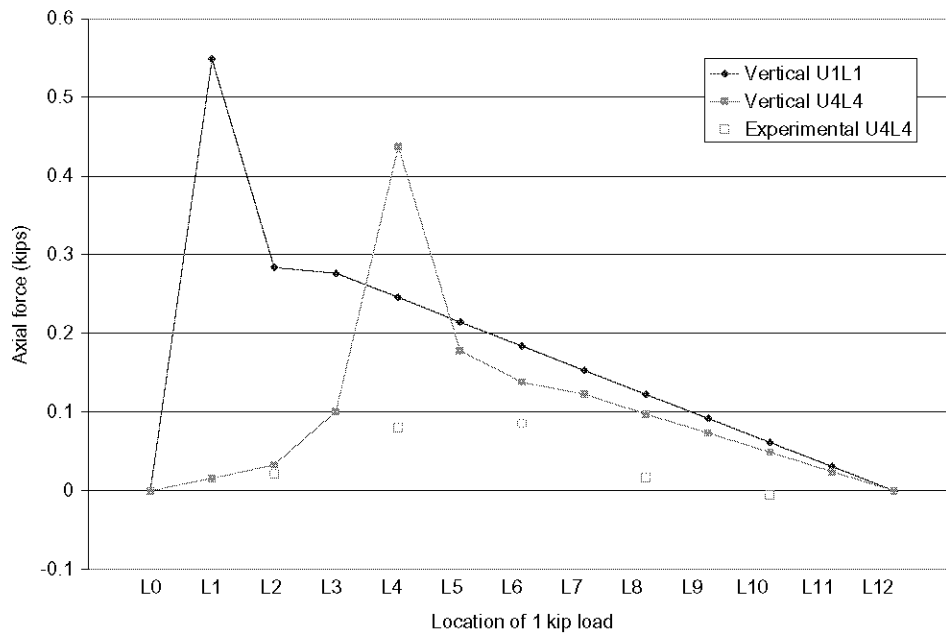

Figure 23. Influence lines for axial forces in vertical elements U_1L_1 and U_4L_4

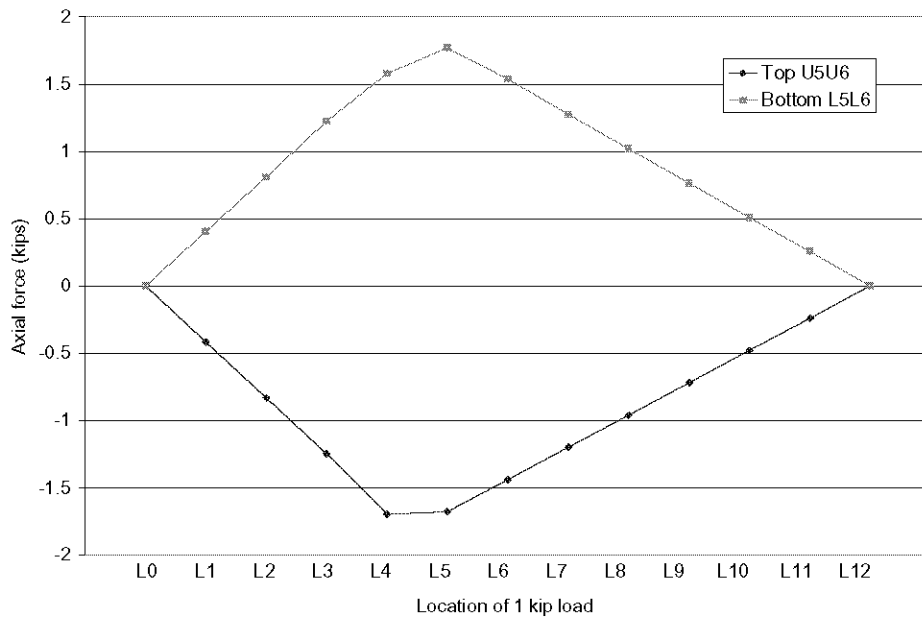

Figure 24. Influence lines for top chord U_5U_6 and bottom chord L_5L_6

Figures 25, 26, and 27 show time histories of member axial forces and vertical displacements obtained from the physical load tests. “Plateaus” in the data correspond to periods during which the truck was stopped with its center of gravity at the nodes. The fluctuations at the ends of each plateau result from the truck decelerating/accelerating.

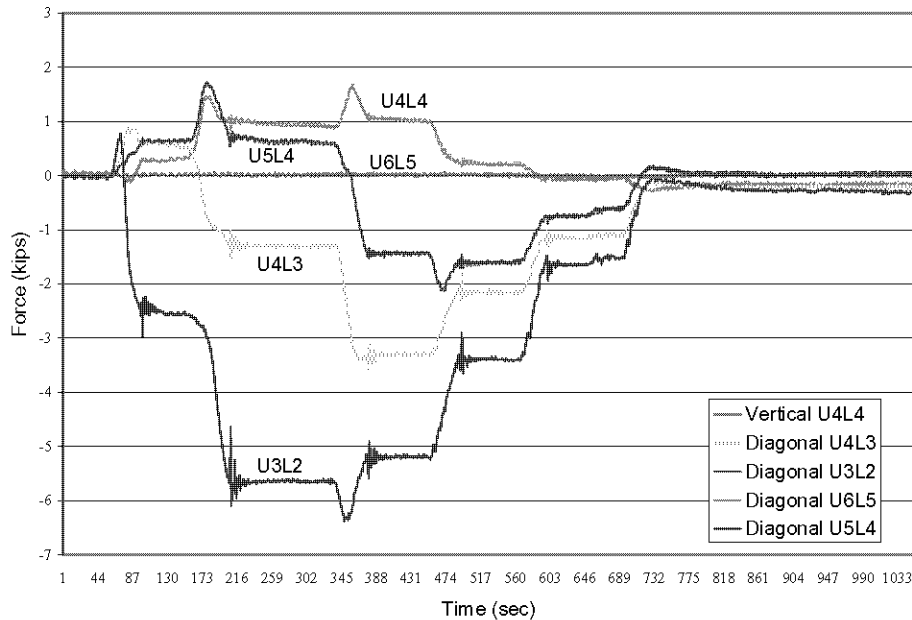

Figure 25. Axial force in wood elements instrumented with strain transducers, Run 1 of Test 2

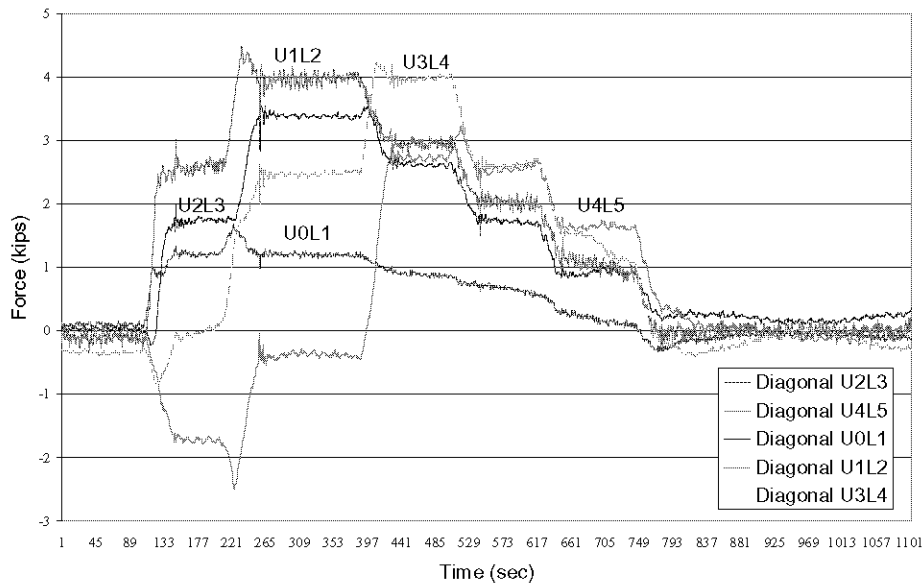

Figure 26. Axial force in iron tension rods, Run 1 of Test 2

Figure 25 shows that the force in diagonal U_6L_5 was practically zero for all positions of the truck. Assuming that the transducer was functioning properly, this would indicate that the diagonal was effectively loose. Diagonal U_5L_4 shows the greatest reversal of force from the live load, which shows the need for a compressive force from dead load to prevent looseness. The maximum

compressive force from the moving load occurs in diagonal U_3L_2 . The vertical member, U_4L_4 , remains in tension for all positions of the moving load.

Figure 26 shows that tension rod U_4L_5 had the greatest force reversal from the live load, which shows the need for a tensile force from the dead load to prevent buckling. Diagonal U_0L_1 had a tensile force for all positions of the load.

Figure 27 shows the experimental vertical displacements at the midspan of the east and west trusses. The displacements of the two trusses should not be the same for any one position of the load because of the skewness of the bridge. The displacements of the west truss would be symmetric if the truss was truly symmetric, which is not possible due to variations in the member sizes and in the mechanical properties of wood.

The experimental load effects in Figures 25, 26, and 27 are for a 12-ton truck traversing the span. If it is assumed that each truss carried half the truck weight, then the experimental responses at the “plateaus” may be divided by 12 and compared with the analytical influence lines. These experimental responses are plotted together with the analytical influence lines in Figures 18 to 23.

Experimental and analytical influence lines for midspan vertical displacement (Figure 18) and for axial forces in members U_3L_2 (Figure 23) and U_4L_5 (Figure 22) are in very good agreement. Experimental and analytical influence lines for axial forces in the other members that were instrumented show greater differences, although variations with position are similar. Tables 13 and 14 compare analytical and experimental axial stresses in the instrumented members for the five locations at which the truck was stopped. Although the plane frame model captured the overall bridge behavior in terms of midspan vertical displacement, the analytical and experimental results for member axial forces and stresses were not in uniform agreement for all members.

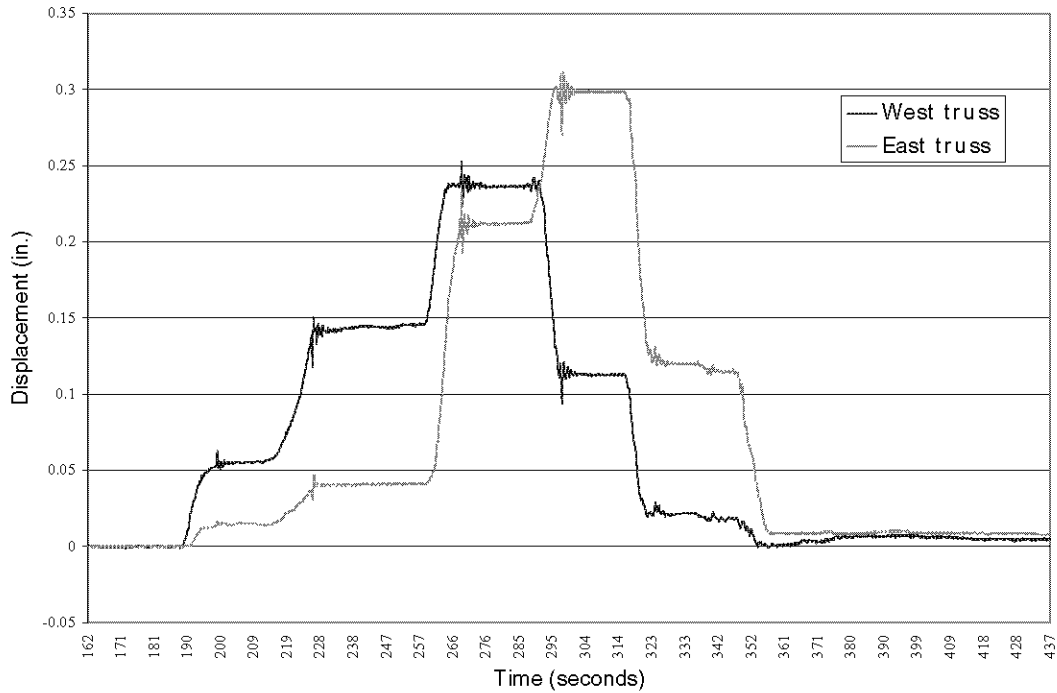

Figure 27. Midspan vertical displacement under 12-ton truck, Run 1 of Test 2

Table 13. Experimental axial stress in elements during Run 1 of Test 2 (negative value indicates compression)

Element	Location of 1 kip load				
	L2	L4	L6	L8	L10
Vertical U_4L_4	0.00546	0.0204	0.0217	0.00420	-0.00129
Compression diagonal U_3L_2	-0.0370	-0.0818	-0.0753	-0.0491	-0.0228
Compression diagonal U_4L_3	0.0103	-0.0225	-0.0579	-0.0377	-0.0192
Compression diagonal U_5L_4	0.0144	0.0144	-0.0312	-0.0354	-0.0156
Compression diagonal U_6L_5	0	0	0	0	0
Tension rod U_0L_1	0.827	0.827	0.614	0.425	0.118
Tension rod U_1L_2	1.654	2.718	2.032	1.394	0.685
Tension rod U_2L_3	1.489	2.859	2.245	1.465	0.827
Tension rod U_3L_4	0	2.103	3.382	2.245	1.134
Tension rod U_4L_5	-1.891	-0.425	2.954	2.765	1.820

Table 14. Live load axial stress in elements by computer analysis (negative value indicates compression)

Element	Location of 1 kip load				
	L2	L4	L6	L8	L10
Vertical U ₄ L ₄	-0.00831	0.111	0.0351	0.0247	0.0124
Compression diagonal U ₃ L ₂	0.0344	-0.0949	-0.0695	-0.0463	-0.0231
Compression diagonal U ₄ L ₃	0.0243	-0.0931	-0.0812	-0.0547	-0.0273
Compression diagonal U ₅ L ₄	0.0314	0.0774	-0.108	-0.0676	-0.0338
Compression diagonal U ₆ L ₅	0.0701	0.142	-0.175	-0.141	-0.0707
Tension rod U ₀ L ₁	2.310	1.880	1.407	0.938	0.469
Tension rod U ₁ L ₂	4.017	2.912	2.188	1.460	0.730
Tension rod U ₂ L ₃	0.305	3.094	2.344	1.556	0.778
Tension rod U ₃ L ₄	-1.085	3.763	2.464	1.666	0.833
Tension rod U ₄ L ₅	-1.232	-1.191	3.458	2.224	1.112

Uniform Live Load Analyses

To help assess Sherman's design, it is meaningful to estimate maximum normal stresses in the members under a combination of dead load and a common nineteenth century uniformly distributed design live load. At the end of the nineteenth century, Ketchum proposed an 80 lbs/ft² live load for spans under 75 ft, 55 lbs/ft² for spans reaching 200 ft, and a linear variation in load for spans between 75 and 200 ft³⁵. A conservative live load of 80 lbs/ft² was assumed for the Harshman Bridge.

The two uniform live load cases modeled for the Harshman Bridge were a uniform live load of 80 lbs/ft² over the entire span of the bridge, and a uniform live load of 80 lbs/ft² over half the span of the bridge. Both live load cases were analyzed with the dead load on the bridge as well. Maximum normal stresses from axial forces and bending moments for a set of members are given in Table 15.

³⁵ M.S. Ketchum, *The Design of Highway Bridges and the Calculation of Stresses in Bridge Trusses* (New York: The Engineering News Publishing Company, 1909).

Table 15. Results of uniform live load analyses

Element	Stress due to 80 psf over half-span	Stress due to 80 psf over full span
	(ksi)	(ksi)
Top chord U ₅ U ₆	-0.646	-0.812
Top chord U ₆ U ₇	-0.505	-0.812
Bottom chord L ₅ L ₆	0.760	1.030
Bottom chord L ₆ L ₇	0.717	1.030
Vertical U ₇ L ₁	0.400	0.465
Vertical U ₆ L ₆	0.114	0.166
Vertical U ₁₁ L ₁₁	0.261	0.465
Compression diagonal U ₂ L ₁	-0.317	-0.394
Compression diagonal U ₆ L ₅	0.139	-0.160
Compression diagonal U ₆ L ₇	-0.343	-0.150
Compression diagonal U ₁₀ L ₁₁	-0.254	-0.394
Tension rod U ₀ L ₁	11.12	13.09
Tension rod U ₄ L ₅	3.60	8.26
Tension rod U ₈ L ₇	7.91	8.10
Tension rod U ₁₂ L ₁₁	7.50	13.09

Allowable normal stresses in pine range between 850 psi and 1750 psi, and most of the elements fell well below the minimum value of this range. The exception to this was the bottom chord of the truss, which fell in the lower part of this allowable range. The allowable axial stress in wrought iron ranges between 13000 and 15000 psi, and maximum stresses in the tension rods were within this range.

Live load vertical displacements at midspan for the two uniform live load conditions were 0.5” for the load over half-span and 1.0” for the load over the full span. That is, the maximum live load displacement was approximately 1/1200 of the span, which means that the bridge has a high, acceptable live load stiffness.

Table 15 shows that the model predicted a *tensile* force in diagonal U₆L₅ for an 80 lbs/ft² live load over half the span. This was not possible given the simple bearing connections used for the wood diagonals, which meant the model was inappropriate for an 80 lbs/ft² live load over half the span. By setting the total dead load and live load axial force in member U₆L₅ equal to zero, the magnitude of the uniformly distributed live load over half the span that caused this condition could be inferred. For the plane frame model used, it was estimated that that a load of 57 lbs/ft² over half the span would cause member U₆L₅ to become loose. Similarly, a concentrated vertical load of 9.5 kips at node L₅ would cause compression diagonal U₆L₅ to become loose. This value was significantly lower than the 12 kips used in the experiment, which may explain the zero force in the compression diagonal in the results (Figure 25).

Of course the capacity of a bridge also depends on the capacity of its floor system. Sherman used closely-spaced girders supported by wrought iron hangers. With such supports, the girders may

be modeled as simply supported beams. With such a model, the maximum flexural normal and shear stresses for dead load plus an 80 lbs/ft² live load are 1083 lbs/in² and 72.2 lbs/in², respectively. These are below the typical allowable stresses for red oak, which are 1100 lbs/in² and 155 lbs/in², respectively. The steel beams (W12x35 sections) were recently added to help carry the loads. These steel beams decrease the maximum flexural normal stresses in the wood beams, but because of the connection detail used, they increase the maximum shear stress in the wood girders (which have to support the weight of the steel beams). The wood girders and the steel beams share in carrying live loads in proportion to their flexural stiffnesses. For example, the fraction of the total load carried by the wood girders is equal to the ratio:

$$\frac{E_w I_w}{E_w I_w + E_s I_s}$$

in which E_w and E_s are the modulus of elasticity of the wood and steel sections and I_w and I_s are the moments of inertia of the wood and steel sections. Substituting the actual values of these parameters shows that the steel beam reduces the maximum normal stress in the wood girder by 85 percent. Conversely, the maximum shear stress in the wood girder increases by approximately 8 percent.

Construction and Tightening the Nuts on the Rods

The construction process for the Harshman Bridge, as well as most covered bridges, is unknown, particularly at the time the nuts were tightened. It is very likely that falsework was built with the desired camber. The chords, verticals, and diagonal members were then placed and connected, but the framework did not support its self-weight, which was carried by the falsework. The rods were probably placed next. The nuts could not be tightened as in a Howe or Pratt truss because tightening would simply distort a panel since the connections of the wood diagonals precluded tension. Therefore it is likely that the nuts were only “snug-tightened” when the falsework was in place. As the falsework was removed, the dead load was transferred to the truss. The two analytical models presented here estimate the dead load member forces for such a construction scenario.

Once the self-weight was transferred to the truss, further tightening of the nuts would change the dead load forces in the members. It is not certain whether this could have been achieved with manual tightening methods. Moreover, there do not seem to be clear advantages for doing so for a Childs-type truss, since the tensile iron diagonals and the compressive wood diagonals were already able to contribute to carrying the live load.

Nonetheless, to estimate the effects of tightening a nut with the falsework removed and the compressive wood diagonals active, analyses of the plane frame models were performed for effective unit loads from tightening nuts. Figure 28a shows member axial forces and vertical displacements of L_1 and L_2 from unit effective forces from tightening rods U_1L_2 and $U_{11}L_{10}$ at the same time. Figure 28b shows member axial forces and vertical displacements of nodes L_4 and L_5 from unit effective forces from tightening rods U_4L_5 and U_8L_7 at the same time. The

figures show that tightening the rods increased dead load tensile forces in the rods, decreased the dead load compressive forces in the wood diagonals and decreased the dead load tensile forces in the verticals. Member axial forces in adjacent panels were an order of magnitude smaller than those in the panel where the rods were tightened. The tightening action caused very small upward vertical displacements of the nodes, therefore tightening was not an effective method to induce camber in the truss.

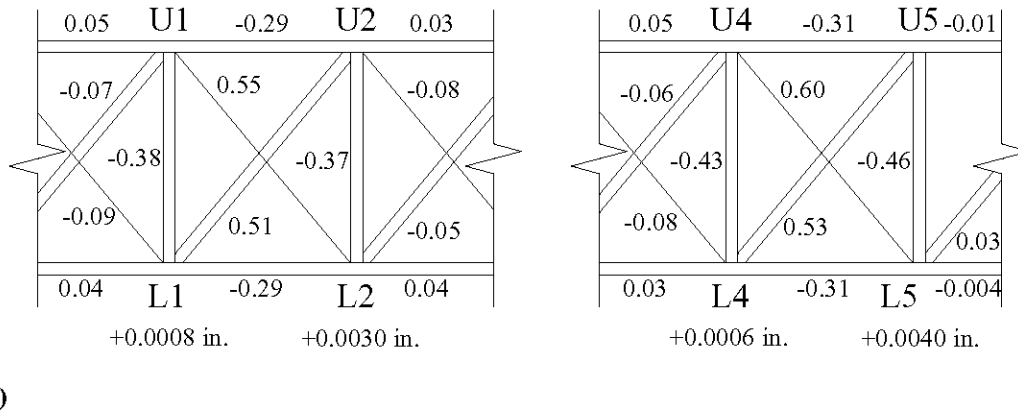

Figure 28. Forces (in kips) and displacements (in inches) in truss elements resulting from tightening of U₁L₂ (left) and U₄L₅ (right)

Time-Dependent Behavior of the Harshman Bridge

Wood has time-dependent stress-strain behavior at ambient temperatures, thus it is can be considered to be a viscous material. For example, if a constant stress is applied to wood, the strain increases with time. This phenomenon is called creep, and it occurs in three stages; the first stage of creep deformation occurs when the structure is first loaded, the second stage is reached when the rate of creep begins to approach zero, and third stage, which occurs under large loads over long periods of time, is when the rate of creep increases quickly to failure. The second stage is typically reached within a short period of time, and it can last for many years.³⁶

Viscous stress-strain (constitutive) models are needed in order to obtain time histories of the responses such as nodal displacements and element forces. These viscous constitutive models lead to ordinary differential equations for the effects of any loading. In lieu of such models, to obtain a qualitative sense of the effects of creep, it was assumed that all the wood elements have a creep strain, ϵ_{creep} , equal to ± 0.0005 , and that all the iron members do not creep. These assumed wood creep strains were used to compute effective nodal loads for a computer analysis of the plane frame model. The computed changes in member forces due to creep are given in Table 16.

³⁶ Forest Products Laboratory, *Wood Handbook, Wood as an Engineering Material* (Madison, WI: USDA Forest Service, 1999).

Table 16. Element forces due to creep (negative value indicates compression)

Element	Change in member force due to assumed creep strains (kips)
Top chord	
U ₀ U ₁	-8.8
U ₁ U ₂	-7.2
U ₂ U ₃	-6.5
U ₃ U ₄	-6.4
U ₄ U ₅	-6.5
U ₅ U ₆	-0.6
Bottom chord	
L ₀ L ₁	-9.0
L ₁ L ₂	-7.5
L ₂ L ₃	-6.9
L ₃ L ₄	-6.4
L ₄ L ₅	-5.7
L ₅ L ₆	-1.2
Vertical	
U ₀ L ₀	-13.5
U ₁ L ₁	-25.0
U ₂ L ₂	-21.5
U ₃ L ₃	-20.3
U ₄ L ₄	-19.6
U ₅ L ₅	-9.8
U ₆ L ₆	-4.6
Compressive diagonal	
U ₁ L ₀	16.7
U ₂ L ₁	13.6
U ₃ L ₂	12.4
U ₄ L ₃	12.3
U ₅ L ₄	10.8
U ₆ L ₅	3.7
Tension rod	
U ₀ L ₁	15.8
U ₁ L ₂	13.4
U ₂ L ₃	12.0
U ₃ L ₄	11.9
U ₄ L ₅	11.4

These changes in force may be compared with the dead load forces given in Table 3. Qualitatively, creep decreases the dead load compressive axial forces in the wood diagonals and increases the tensile axial forces in the iron diagonals. Thus, the behavior of the Harshman

Bridge approaches that of a single diagonal Pratt truss, but with *compressive* vertical elements. Of course, the analysis with the assumed uniform creep strain of ± 0.0005 is not strictly valid because it predicts changes in the axial forces in the wood diagonals that are larger than the dead load compressive axial forces. In addition, although the assumption that iron does not creep at ambient temperatures is appropriate, the rods induce compressive stresses perpendicular to the grain of the chords. Thus the axial forces in the rods may be affected by (perpendicular to the grain) creep in the chords. Nonetheless, the qualitative effects of creep predicted by the model seem realistic.

Displacements generated by the analysis were perhaps the most interesting results. For the assumed creep strain of 0.0005, the predicted downward vertical displacement at midspan was 1.8". Clearly, this shows why bridges were built with significant camber, to offset the displacement that would occur over time due to creep (and shrinkage).

In both the Pine Bluff Bridge (see HAER No. IN-103) and Eldean Bridge (see HAER No. OH-122), creep caused a loss of prestressing forces in the truss forms. Although the Harshman Bridge was not prestressed, these results could correspond to the loss of dead load tensile force in the verticals due to creep. The possibility for slackness, especially in the counter braces at the end spans, was noted for Pine Bluff Bridge and Eldean Bridge. This observation corresponds with the results of the Harshman Bridge analysis, where creep reduces the compressive forces in the compressive diagonals. For Long and Howe truss forms, the effects of creep could be offset by routine retightening of the prestressed elements of each form.

Of the three truss forms—Howe, Long, and Childs—different effects were observed as a result of shrinkage. The Eldean Bridge, lacking any iron elements, saw no significant stresses as a result of shrinkage because all elements possess the same physical properties. The Pine Bluff Bridge, on the other hand, was affected by shrinkage due to the different physical properties possessed by the iron and wood. The Harshman Bridge, with its iron tension rods, would likely see resultant changes in forces due to shrinkage.

Skewness

One final structural aspect of the Harshman Bridge that should be addressed is its skewness. As noted earlier, the two trusses of the bridge are offset from one another by one panel, and this has some effects on the behavior of the bridge. However, this behavior was not taken into account in any of the structural analyses because two-dimensional models were used. Three-dimensional models would be needed to predict the effects of skewness on the structural behavior of the bridge.

Due to its skewness, any load traversing the Harshman Bridge causes unequal deflections in the two trusses because the girders frame into different panel points of the two trusses. Frames connect the two trusses. The unequal vertical displacements at the two bases of a frame do not induce moments in the frame if the bases are assumed to be "pinned." In this case, the unequal vertical displacements will not cause significant load-carrying interaction between the east and

west trusses. If the bases are assumed to be rotationally fixed, then the relative vertical base deflections will induce moments in the cross frames and affect the way the east and west trusses carry a load traversing along the centerline of the skew bridge.

One possible benefit of skewness is that a large live load will not cause the compression diagonals on both the east and west truss to become loose at the same time because of the one panel offset.

Conclusions and Observations

The Childs truss was patented at a time when prestressed truss forms were in use. The 1830 Long truss and the Howe truss (1840) forms were both prestressed so that the diagonal members were in compression. The 1839 Long truss and the Pratt truss (1844) placed the diagonals in tension when prestressed. In all of these forms, prestressing was critical to ensure that the two diagonals in each panel were both active. The Childs truss, on the other hand, did not require prestressing for both diagonals to be active under a load; for example, a live load at midspan created a compressive force in the wood diagonals and a tensile force in the iron rods. A similar live load in the other trusses caused a decrease in the precompression of the counter-diagonals of the 1830 Long and Howe and a decrease in the pre-tension of the counters in the 1839 Long and Pratt. The Childs truss may not have possessed the same ease of construction as the Howe truss, but the choice of materials to correspond with the forces induced under normal loads was a reasonable alternative to prestressed truss forms.

The Harshman Bridge, lacking the connection details of Horace Childs' patent, was more likely an adaptation of the Childs truss by Everett Sherman than an actual example of the Childs truss form. Another innovation of Sherman's seems to be the decrease in the cross-sectional areas of the diagonal elements. However, like the Childs form, Sherman does omit the tension rods in the center panel where the compression diagonal was at the greatest risk of becoming loose.

Tightening of tension rod U_0L_1 resulted in a force of 2300 lbs. This experiment was intended to model tightening of the nuts when the wood diagonals were active in resisting dead load.

For the dead load analysis, the plane truss model and plane frame model yielded similar results, with the best agreement in the top and bottom chord stresses, less in the verticals, and least in the compression diagonals and tension rods. Maximum forces under dead load conditions were over 50 kips for both the top and bottom chord, about 10 kips for the verticals, about 23 kips for the compression diagonals, and 9.3 kips for the tension rods. The ratio of vertical components of the forces in the diagonals was assumed to be proportional to the stiffnesses of the members for the plane truss analysis, but the plane frame analysis yielded higher axial forces in the tension rods. Bending moments resulting from the plane frame analysis contribute between 10 and 40 percent to the total stress in each element. The plane truss model estimated a vertical displacement at midspan of 0.834", and the plane frame model predicted a 0.773" deflection.

The first live load case studied was a unit live load placed at midspan. As with the dead load analyses, there was good correspondence in the results of the two models, particularly in the chord forces. The forces in verticals, compression diagonals and tension rods had less agreement. Bending moments in the plane frame model contributed between 20 and 60 percent to the total element stress in the live load case, a higher percentage than in the dead load analysis. Midspan vertical displacement was 0.0308" for the plane truss model and 0.0209" for the plane frame model.

Influence lines were drawn for a number of truss elements by placing a 1 kip vertical live load at different nodes across the span of the bridge. These results were used for comparison with the results of the physical experiments. For the most part, the influence lines successfully predicted the trends in element forces, but values did not always correspond. The maximum force in a compression diagonal under the experimental loads was 6 kips in member U_3L_2 , and looseness (zero force) in compression diagonal U_6L_5 . For the tension rods, maximum forces of about 4 kips were reached in elements U_1L_2 and U_3L_4 . Maximum midspan vertical displacement due to the 12-ton truck was 0.27", whereas live load analyses predicted midspan vertical displacements of 0.344" and 0.370" for the plane frame and plane truss models, respectively.

A uniform live load of 80 lbs/ft², a typical nineteenth century design live load, was placed over the half-span and the full span of the bridge for analysis. For the load over the entire span, maximum stresses were 1 ksi in the bottom chord, 0.8 ksi in the top chord, 0.5 ksi in verticals, 0.4 ksi in the compression diagonals, and 13 ksi in the tension rods. All of these values are within or below the acceptable range of values for pine, or wrought iron in the case of the tension rods. The uniform live load over half the span predicts looseness in compression diagonal U_6L_5 , which corresponds with the experimental results. Calculations were made to estimate the minimum loads needed to create looseness in compression diagonal U_6L_5 . This condition could be generated by a uniform live load over half-span of 57 lbf/ft² or a concentrated load of 9.5 kips at node L_5 . Maximum stresses in the wood girders with the steel beams were also checked, and these calculations indicated that the steel beams increase the maximum shear stress by 8 percent, but reduce the normal stress in the girders by 85 percent.

A tightening analysis was performed to predict the behavior of the Harshman Bridge for the condition of the truss carrying the dead load. Though little is known about the construction process of this bridge truss, it was assumed that the nuts of the rods were snug tightened while the dead load was not active. The analysis indicated an increase in the tensile forces of the tension rods, a decrease in the compressive forces of the compression diagonals, and a decrease in the tension of the verticals due to tightening of the rod in a panel. In adjacent panels, forces were an order of magnitude smaller. Maximum vertical displacements due to tightening in one panel were very small, on the order of 0.001" per 1 kip effective tightening force.

Creep analyses were performed assuming a ± 0.0005 strain due to creep. Unlike the all-wood Long truss form, this analysis indicated that the different material properties (iron and wood) in the Harshman Bridge allow creep in the wood to cause a redistribution of forces. A comparison of the creep analysis (using the assumed creep strain) to the results of the dead load analysis (with no creep strain) indicates that the compression diagonals would be relieved of a significant

amount of their compressive force, the verticals would reverse signs from tension to compression, and the tension in the rods would increase. A very large vertical displacement at midspan of 1.8" downward was predicted.

Overall, there was good correspondence between the analytical predictions of the models and the experimental measurements taken on the Harshman Bridge. The excellent condition of this bridge, which is over a century old, merits attention and praise, and it serves as an outstanding example of why efforts should be made to conserve the engineering landmarks of our past.

Sources

- Allen, Richard Sanders. *Covered Bridges of the Middle West*. New York: Bonanza Books, 1970.
- American Wooden Bridges*. New York: American Society of Civil Engineers Historical Publication, 1976.
- Chamberlain, Dann. "Covered Bridges of Preble County, Ohio." *Covered Bridge Topics* 15 (July 1957): pp. 5, 7.
- Childs, Horace. U.S. Letters Patent No. 4,693, 12 August 1846.
- Cogswell, Leander W. *History of the Town of Henniker, Merrimack County, New Hampshire 1735 to 1880*. Concord: Republican Press Association, 1880.
- Dreicer, G.K. "The Long Span, Intercultural Exchange in Building Technology." Ph.D. diss., Cornell University, Ithaca, NY, 1993.
- Eaton Democrat* (Eaton, Ohio), 1894.
- Engineering News and American Contract Journal* (October 28, 1882).
- _____ (November 11, 1882).
- _____ (December 2, 1882).
- _____ (December 16, 1882).
- Forest Products Laboratory. *Wood Handbook, Wood as an Engineering Material*. Madison, WI: USDA Forest Service, 1999.
- Gasparini, D.A. and C. Provost. "Early Nineteenth Century Developments in Truss Design in Britain, France, and the United States." *Journal of the Construction History Society* 5 (1989): pp. 21-33.
- Gasparini, D.A. and D. Simmons. "American Truss Bridge Connections in the 19th Century, Part I: 1829-1850." *American Society of Civil Engineers Journal of Performance of Constructed Facilities* II, no. 3 (August 1997): pp. 119-129.
- _____. "American Truss Bridge Connections in the 19th Century, Part II: 1850-1900." *American Society of Civil Engineers Journal of Performance of Constructed Facilities* II, no. 3 (August 1997): pp. 130-140.
- Genealogical Records, New Hampshire Antiquarian Society, 300 Main Street, Hopkinton, NH.

Hiestand, Ione Sell. *Preble County, Ohio*. Eaton, Ohio: Preble County Historical Society, 1992.

“Horace Childs,” in *Biographical Review of Merrimack and Sullivan Counties, New Hampshire*. Boston: Biographical Review Publishing Company, 1897.

Ketcham, Bryan E. *Covered Bridges on the Byways of Ohio*. Oxford, OH: Oxford Printing Company, 1969.

Ketchum, M.S. *The Design of Highway Bridges and the Calculation of Stresses in Bridge Trusses*. New York: The Engineering News Publishing Co., 1909.

Long, S.H. *Description of Col. Long’s Bridges Together with a Series of Directions to Bridge Builders*. Concord, NH: Star and Universalist Press, 1836.

Perry, Wayne. “Sketches of the Childs Truss.” *Covered Bridge Topics* 44 (Summer 1985): pp. 8-11.

Robinson, F.B. “Map of Preble County, Ohio, 1897.”

Schlotterbeck, Seth S. *Covered Bridges of Preble County, Ohio*. Eaton, OH: Preble County Historical Society, 1976.

Sherman, Everett. U.S. Patent No. 191,552, 5 June 1877.

Simmons, David A. “Unique Covered Bridge in Delaware County.” *Ohio County Engineers News*, Spring 1991.

Skinner, R.J. “Map of Preble County Ohio.” Hamilton, OH: R.J. Skinner, 1858.

Wood, Miriam. *The Covered Bridges of Ohio, an Atlas and History*. Columbus: Old Trail Printing Company, 1993.

_____. “A History of Covered Bridges in Preble County, Ohio.” *Connecticut River Valley Covered Bridge Society Bulletin* 9 (Fall 1962): p. 6; (Winter 1963): pp. 3-4.

_____. National Register of Historic Places Inventory-Nomination Form: “Harshman Covered Bridge,” Preble County, Ohio, 1970.